

Digital Multimeter
DMM 5000

Instruction Manual

PREMA Präzisionselektronik GmbH
Robert-Bosch-Str. 6 · D-55129 Mainz-Hechtsheim
or Postfach 42 11 53 · D-55069 Mainz · Germany
Tel. (06131) 5062 - 16 or 5062 - 0
Tx. 4 187 666 prem d · Fax (06131) 5062 - 22

PREMA PRECISION ELECTRONICS INC.
4650 Arrow Highway, Building E-5
Montclair, CA 91763-1217, Fax (909) 625 - 2098
Telephone (909) 621 - 7292 or (800) 441- 0305

CONTENTS

=====

Chapter	page
1.0 Introduction	1/1
1.1 General Description	
1.2 Measuring Principle	1/2
2.0 5000 Specifications	2/1
2.1 DC Volts	
2.2 Resistance	2/4
2.3 Alternating Voltage	2/6
2.4 DC Current	2/8
2.5 AC Current	2/9
2.6 Trigger Input	2/11
2.7 Scanner (Option 6000/01)	2/12
2.8 IEEE 488 Bus Interface	2/14
2.9 General	2/15
3.0 Commencing Operation	3/1
4.0 Keyboard and Integration Setting	4/1
5.0 Numeric Display	5/1
6.0 Offset Correction	6/1
7.0 Error Messages and Self-Test	7/1
7.1 Error Messages	
7.2 Self-Test	7/2
8.0 Operating Instructions	8/1
8.1 Operating Instructions DC Voltage	
8.2 Operating Instructions Ohm/kOhm	8/3
8.3 Operating Instructions Vac	8/4
8.4 Operating Instructions mAdc and mAac	8/5

9.0 Operating Instructions for scanner/multiplexer	9/1
10.0 Operating Instructions for External Triggering	10/1
11.0 IEEE 488-Bus-Interface	11/1
11.1 Programming the Digital Multimeter via IEEE Bus	
11.2 Device Messages transmitted from the Multimeter	11/6
11.3 Programming examples for the IEEE 488 Bus	11/10
12.0 Calibration	12/1
12.1 Calibrating DC Voltage	12/2
12.2 Calibrating Resistance	12/3
12.3 Calibrating AC Voltage	
12.4 Calibrating DC and AC Current	
13.0 Setting up a Self-Sufficient System for Automatic Acquisition of Measurement Data	13/1
13.1 Description of the Measuring Set-Up	
13.2 Example of a Measuring Sequence	13/2
14.0 Accessories	14/1
14.1 Mating Plug for Sub-D	
14.2 Adaptercard	
14.3 Rack Mounting Kit	
15.0 Circuit Diagrams	15/1

1.1. General Description

The P R E M A 5000 DMM/Scanner is a fully equipped 6 1/2 digit digital multimeter with an outstanding price to performance ratio. It features all characteristics of a high class device normally available only for a higher price, such as 1 GOhm input resistance up to +/- 2V and 100 nV resolution for direct voltage measurements, genuine rms alternating voltage and current measurements and resistance measurements with 1mOhm resolution. An additional offset correction facility permits compensation of thermoelectric EMFs for direct voltage measurements, with the measuring leads shorted, and correction for the line resistance when making resistance measurements. The PREMA multiple ramp method for analog to digital conversion ensures excellent linearity and longterm accuracy, with continuous integration of the signal being measured, for averaging out any interference, without falsifying breaks.

The digital multimeter is equipped with programs which include start (triggered) operating mode and signal integration over fixed selected times.

The multimeter can be equipped with a 10-channel four-pole network multiplexer (option 6000/01). The maximum voltage which can be switched is 125 V, the maximum current which can be switched is 2 A and the thermoelectric EMFs at the switch contacts are smaller than 1 μ V.

An IEEE 488 bus interface is a standard feature which permits remote control and remote monitoring of all functions of the multimeter including the digital calibration. Excellent electrical isolation between the measured signal input sockets and the interface plug connector permits clean 100 nV resolution for direct voltage measurement even in system operation.

A simple digital calibration procedure simplifies the alignment procedure for the multimeter. A single nominal value, which may lie anywhere within a wide range and can be entered via the keyboard or via the IEEE 488 bus, suffices to calibrate a measuring range. Each measuring range of each function can be recalibrated independently. A covered mechanical switch on the rear of the multimeter gives protection against unintentional destruction of the correction factors.

The uncompromising utilization of microelectronic integration has drastically reduced the number of discrete electronic components in this device. This has facilitated servicing and has considerably enhanced reliability.

1.2. Measuring Principle

The P R E M A multiple ramp method for analog to digital conversion (German patent No. 2114 141) is used in the Model 5000. It is the basis for a reliable digital multimeter featuring excellent linearity and longterm accuracy, with continuous integration of the measured signal to average out any interference, without falsifying breaks.

An amplifier which operates as integrator with the capacitor C (fig.1) continuously integrates a current I_e which is proportional to the voltage to be measured. This procedure has a very good linearity, because the input voltage does not need to be switched away, which would otherwise cause an error which changes with the magnitude of the input voltage, due to the varying switching surges caused by the capacitance of the transistors used as signal switches in presentday circuit practice. The capacitor is periodically discharged (fig.2) by a current I_{ref} from a reference voltage source which has opposite polarity with respect to the signal voltage being measured, U_{ref} (discharge times t_1 to t_n). Before the start of a down integration, the comparator determines the sign of the input voltage and thus defines the polarity of the reference voltage. The same reference voltage is used for both polarities and thus the same down integration resistor, so that the numerical readout value is closely the same when polarity of the input voltage is reversed. The end of a down integration is defined by coincidence of comparator response and a pulse flank of the clock oscillator. Since the total change of charge on the capacitor during one measuring cycle is zero, it follows that

$$\frac{1}{T} \int_0^T U_e dt = -\frac{R_e}{R_0 T} U_{ref} \sum t_i$$

In other words, the sum of the discharge times t_i is proportional to the average value of the input voltage, and is displayed as result of the measurement.

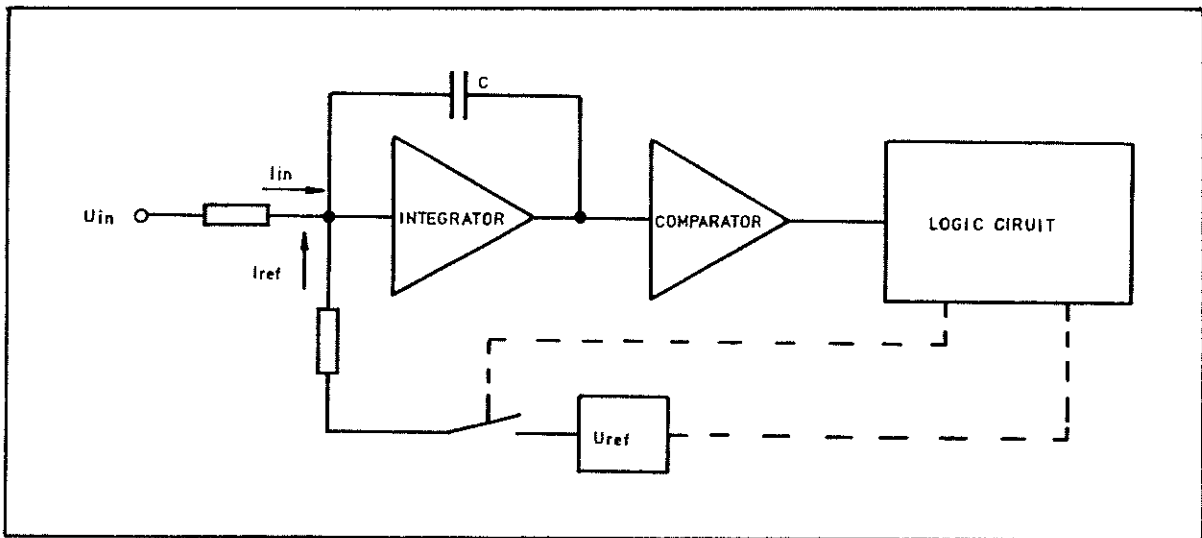

fig.1 Simplified block diagram

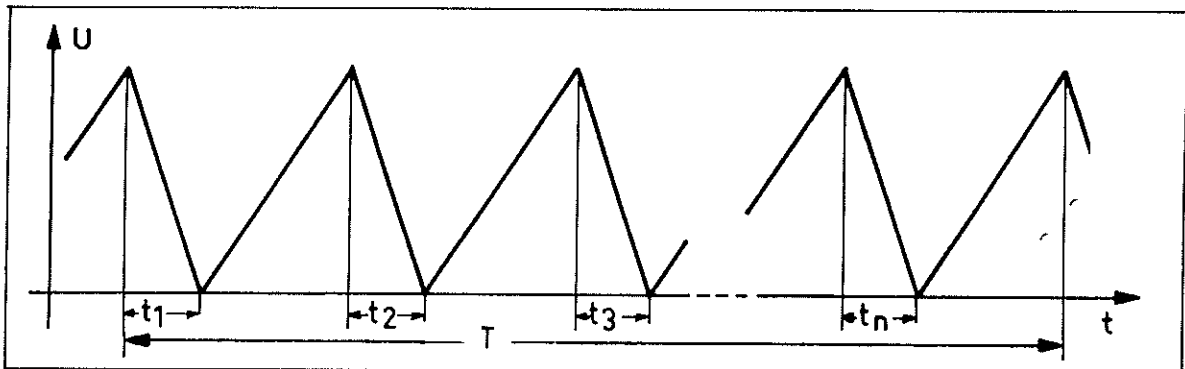

fig.2 Integrator output voltage

In this method of voltage to time conversion, the result is not falsified by the loss factor of the capacitor or by any drift of the capacitance value C . The measurement result is also independent of the frequency of the clock oscillator used for making the time measurement, because T and all t_i are determined with the same frequency. Only modest requirements with regard to drift and speed are imposed on the comparator in the PREMA multiple ramp method, so that a low cost circuit design is possible in spite of the excellent performance as digital voltmeter.

2.0 5000 SPECIFICATIONS2.1 DC VOLTS

RANGES +/-0.2V; +/-2V; +/-20V; +/-200V;
 +/-1000V 2)

INTEGRATION TIMES (sec.).....	0.1	1+10
FULL SCALE (except 1000V)....	199 999	1999 999
1000 V Range with out built-		
in Scanner Opt.6000/01.....	100 000	1000 000
1000 V Range with built-		
in Scanner Opt.6000/01	125 00	125 000
RESOLUTION	1 μ V	100nV

RANG SELECTION..... manual, automatic or by remote-
 control

ACCURACY +/-(% of reading (%rdg.) + % of full scale (%f.s.))
 1),2),4)

	24h 23°C+/-1°C	
RANGE	%rdg.	%f.s.
0.2V	0.005	0.0007
2V	0.003	0.0005
20V	0.005	0.0015
200V	0.005	0.0015
1000V	0.005	0.0015

2)

	1 year 23°C+/-5°C	
RANGE	%rdg.	%f.s.
0.2V	0.012	0.0007
2V	0.010	0.0005
20V	0.012	0.0015
200V	0.013	0.0015
1000V	0.013	0.0015

2)

- 1) Add +/-1 Digit. "Guard" connected to " V/Ohm-LO ". After zeroing
- 2) Max. 125V peak when fitted with the scanner (option 6000/01). 1000V range is dropped.
- 3) Valid for a constant input signal; +/- 0.0005% f.s. during 1s and 0.005% during 100ms must be added after change of the input signal.
- 4) % f.s. relates to scale length of 1 999 999

TEMPERATURE COEFFICIENTS (10°C to 18°C and 28°C to 40°C)

RANGE	+/- (%rdg.+ %f.s.)/ C	
0.2V	0.001	0.00015
2V	0.0003	0.0001
20V	0.001	0.0001
200V	0.001	0.0001
1000V	0.001	0.0001

2)

TEMPERATURE COEFFICIENTS Double the values at
(0°C to 50°C) 10°C to 40°C

ZERO STABILITY

Offsetvoltage (after 1 hour warm-up time)

Temperatur drift less than 0.3 $\mu\text{V}/^\circ\text{C}$
Long term stability better than 5 μV in 90 days

INPUT RESISTANCE

RANGE

+/- 0.2V, +/-2V 1 GOhm

+/- 20V, +/-200V, +/- 1000V .. 10 MOhm

INTERFERENCE REJECTION (Ratio of peak to peak interference
to 1 digit reading error with an
integration time of 1s)

SERIES MODE REJECTION

50/60 Hz power line frequency. better than 60 dB

COMMON MODE REJECTION (Up to 1 kOhm in the "Lo"-lead; guard
connected to the "V-LO"- input socket)

DC Voltage 140 dB

50/60Hz power line frequency.. 140 dB

MEASURING PAUSES 125 ms after range or function
change

MEASURING METHOD..... Fully integrating PREMA multiple
ramp procedure (German Pat. No.
2114141, 2820601C2; US-Pat. No.
3765012, 4361831)

POLARITY CHANGE..... automatic

OVERLOAD PROTECTION

Between "V/Ohm-HI" and
case +/- 1000 V peak tp peak AC
with
max. 60 Hz

DC

Between "V/Ohm-HI" and
"V/Ohm-LO" input +/-0.2V,
+/-2V -range for
60 sec. +/- 1000V 1)
continous +/- 700V 1)
+/-20V, +/-200V, +/-1000V-
range, continous +/- 1000V 1)
when equipped with the scanner
6000/01 in all ranges
continous +/- 125Vp with the restric-
tion of 1 000 000 x Vpp x Hz

The "V/Ohm-LO" socket and the "A-LO" socket are connected
together internally in the direct voltage (DC Volts)
function. The maximum permissible current between these
sockets is +/- 0.1 A) (fuse 0.1 A).

Between "V/Ohm/LO" input
and guard 125 V DC or peak

Between guard and case 125 V DC or peak

Between "V/Ohm/LO" and case.. 125 V DC or peak

OVERLOAD INDICATION ERROR 1 in the display

- 1) Max. 125 Vpeak when fitted with the scanner (option 6000/01)
1000 V range is dropped.

TEMPERATURE COEFFICIENTS

(10°C to 18°C and 28°C to 40°C)

RANGE	+/-(%rdg. + %f.s.)/°C	
200 Ohm	0.002	0.0005
2 kOhm, 20 kOhm, 200 kOhm ...	0.0015	0.0005
2 MOhm	0.002	0.0005
10 MOhm	0.01	0.0005

TEMPERATURE COEFFICIENTS

(0°C to 50°C)

Double the values for
10°C to 40°C

CURRENT THROUGH UNKNOWN RESISTOR

RANGE

200 Ohm, 2 kOhm	0.7 mA
20 kOhm	70 μ A
200 kOhm	7 μ A
2 MOhm, 10 MOhm	0.7 μ A

OPEN CIRCUIT TERMINAL VOLTAGE .. about -14 V max.

MEASURING PAUSES 125 ms after range or function
change

OVERLOAD LIMIT +/- 300 V peak 1)

OVERLOAD INDICATION ERROR 1 in the display

1) Max. 125V peak when fitted with the scanner (option 6000/
01). 1000 V range is dropped

2.3 ALTERNATING VOLTAGE

CONVERSION METHOD True rms value for the sum of direct and alternating voltage

RANGES 0.2V; 2V; 20V; 200V; 700 V 2)

FULL SCALE 199999, in the 700V-range: 700 00 2)

INTEGRATION TIMES 0.1s, 1s, 10s

RANGE SELECTION manual, automatic or by remote control

ACCURACY (1 year, 23°C±5°C) ± (% of reading (%rdg.) + % of full scale (%f.s.)) 1),3)

Range	20Hz	45Hz	1kHz	10kHz	20kHz	100kHz
0.2 V	/ 0.5+0.3	/ 0.2+0.1	/ 0.3+0.1	/ -	/ -	/ -
2 V	/ 0.5+0.3	/ 0.2+0.1	/ 0.3+0.1	/ 2+0.4	/ 3+0.4	/ -
20 V	/ 0.5+0.3	/ 0.2+0.1	/ 0.3+0.1	/ 2+0.4	/ 3+0.4	/ -
200 V	/ 0.5+0.3	/ 0.2+0.1	/ 0.3+0.1	/ 5+0.4	/ 8+0.4	/ -
700 V 2)	/ 0.5+0.3	/ 0.2+0.1	/ 0.3+0.1	/ -	/ -	/ -

TEMPERATURE COEFFICIENT (10°C to 18°C and 28°C to 40°C)

kHz	(%rdg. + %f.s.) / °C
0 - 20	0.01 + 0.004
20 - 300	0.04 + 0.005

TEMPERATURE COEFFICIENT (0°C-50°C) double the values for 10°C-40°C

CREST-FACTOR 7 : 1
 The peak value must not exceed 1.5 times the nominal range value or 1000 V, whichever of these limits is the smaller.

- 1) Shield connected to "V/Ohm-LO" input socket, sinusoidal signal greater than 5% of full scale
- 2) The 700 Vac range is not usable when the scanner is fitted. Maximum 125 V
- 3) % f.s. relates to scale length of 1 999 999

INPUT RESISTANCE 10 MOhm/less 60pF

MEASURING PAUSES 625 ms after range or function change

OVERLOAD LIMITS

Between "V/Ohm-HI" and case +/- 1000V peak with max. 60 Hz
or +/- 1000 V DC.

Between "V/Ohm-HI" and "V/Ohm-LO" input +/- 1000 V peak or 700 Vrms
with the restriction of $10\ 000\ 000 \times V \times \text{Hz}$
when equipped with the scanner 6000/01 in all ranges
continons +/- 125 V peak with the
restriction of $1\ 000\ 000 \times V_{pp} \times \text{Hz}$

The "V/Ohm-LO" socket an the "A-LO" socket are connected together internally in the alternating voltage (AC Volts) function. The maximum permissible current between these sockets is +/- 0.1 A (fuse 0.1 A).

Between guard and case 125 V peak

Between guard and "V/Ohm-LO"-input 125 V peak

Between "V/Ohm-LO" and case 125 V peak

TRANSIENT RESPONSE TIME 0.5 s to reach final reading within 0.1%.

OVERLOAD INDICATION ERROR 1 in the display

2.4 DC CURRENT mAdc

RANGES +/- 2mA; +/- 2A
 RESOLUTION 10 nA; 10 μ A
 FULL SCALE 199999
 INTEGRATION TIMES 0.1s, 1s, 10s
 RANGE SELECTION manual, automatic or by remote control
 ACCURACY (1 year, 23°C +/-5°C +/- (%of reading (%rdg.) + % of full scale (%f.s.)) 1),2)
 RANGES %rdg. %f.s.
 +/- 2mA and +/- 2A 0.05 + 0.005
 TEMPERATURE COEFFICIENT
 (10°C to 18°C and 28°C to 40°C)
 2mA and 2A-range (up to 1A) +/- (0.002%rdg. + 0.001 %f.s.)/°C
 TEMPERATURE COEFFICIENT
 (0°C-50°C) double the values at 10°C-40°C
 VOLTAGE BURDEN
 2mA range less 20mV
 2A range less 0.6V
 2A range with option 6000/01
 installed less 1V
 MEASURING PAUSES 125 ms after range or function change
 OVERLOAD LIMITS max. 250V peak peak (fuse 3A)
 (max. 125 V peak, when fitted with the scanner option 6000/01).
 The "V/Ohm-LO" socket and the "A-LO" socket are connected together internally in the direct current function.
 The maximum permissible current between these sockets is +/- 100m (fuse 100mA)
 OVERLOAD INDICATION Error 1 in the display
 1) Add +/- 1 Digit. After autozero.
 2) Guard connected to "V/Ohm-LO" input socket, sinusoidal signal greater then 5% of full scale.

2.5 AC CURRENT mAac

RANGES +/- 2mA; +/- 2A
 RESOLUTION 10 nA; 10 μ A
 FULL SCALE 199 999
 INTEGRATION TIMES 0.1s, 1s, 10s

RANGE SELECTION manual, automatic or by remote control

ACCURACY (1 year, 23°C \pm 5°C) +/- (% of reading (%rdg)
 + % of full scale (%f.s.)) 1)

RANGE	DC+20Hz	20kHz	100kHz
2mA, 2A	/-----0.5+0.07---	/-----5+0.4---	

TEMPERATURE COEFFICIENT
 (10°C to 18°C and 28°C to 40°C)

kHz		(%rdg. + %f.s.)/°C
DC+0.02 - 20	0.01 + 0.004
20 - 100	0.04 + 0.005

TEMPERATURE COEFFICIENT
 (0°C-50°C) double the values for 10°C-40°C

CREST-FACTOR 7 : 1
 The peak value must not exceed 1.5 times the nominal range value.

VOLTAGE BURDEN
 2mA range less 20mV
 2A range less 0.6V
 2A range with option 6000/01
 installed less 1V

MEASURING PAUSES 625 ms after range or function change

1) Guard connected to "V/Ohm-LO" input socket, sinusoidal greater than 5% of full scale.

OVERLOAD LIMITS max. 250V peak (fuse 3A), (max. 125V peak, when fitted with the scanner option 6000/01).
The "V/Ohm-LO" socket and the "A-LO" socket are connected together internally in the direct current function. The maximum permissible current between these sockets is +/- 100mA (fuse 100mA).

TRANSIENT RESPONSE TIME 0.5 s to reach final reading within 0.1%

OVERLOAD INDICATION ERROR 1 in the display

- 1) Guard connected to "V/Ohm-LO" input socket, sinusoidal greater than 5% of full scale.

2.7 SCANNER (Option 6000/01)

TYPE 4-pole 1 of 10

NO. OF CHANNELS 10

CONTACTS PER CHANNEL 4

SWITCH TYPE bistable, mechanical

THERMAL OFFSET less 1 μ V after 1.5h warm-up time

CHANNEL SELECTION via the keyboard as well as via
the IEEE 488 bus

GUARD common guard for all channels

MAX. VOLTAGE 125 V peak with the limitation
1 000 000 x Vpp x Hz

MAX. VOLTAGE BETWEEN ANY
TWO CHANNELS..... 125 V peak with the limitation
1 000 000 x Vpp x Hz

MAX. CURRENT 2 Amp

MAX. SWITCHING POWER 100 VA (non inductive)

TIME BETWEEN 2 SWITCHING
PROCESSES less 100 ms

DELAY OF MEASUREMENT START
AFTER CHANNEL SWITCHING 125 ms for direct voltage,
direct current and resistance
measurements.
625 ms for alternating vol-
tage and alternating current
measurements.

MAX. CONTINUOUS SWITCHING RATE 2 Hz

MAX. LEAD RESISTANCE
(EACH LEAD) 0.3 Ohm

LIFE CYCLES 2 x 100 000 000 (0.1A, 10V=)

INSULATION RESISTANCE BETWEEN
2 CONTACTS 2 GOhm at rel. humidity under 60%

INSULATION RESISTANCE TO
ENCLOSURE 2 GOhm at rel. humidity under 60%

CAPACITY BETWEEN 2 CONTACTS . less 100 pF

CONNECTOR 50-pole subminiatur type D
socket mounted on the rear of
the unit.

2.8 IEEE 488 BUS INTERFACE

OPERATING MODES	Talker/Listener or Talk Only
DECOUPLING	Galvanically insulated from the input stage
OUTPUT INFORMATION	Numerical read out of measurement result, function, range, integration time
INPUT INFORMATION	Function, range, integration time, start command, nominal value for calibration
ADDRESS	From 0 to 30, TALK ONLY, selectable via keyboard
FUNCTIONS	SH1, AH1, T5, L3, RL1, DC1, DT1, SR1
KEYBOARD	Can be switched off via REN, can be switched on via GTL.
END-CHARACTER	9 different terminating character combinations, selectable via keyboard
COMPATIBILITY	IEEE-Standard-488 (1978) and IEC 625 part 1 and 2
BUS CONNECTOR	24 pin compatible to IEEE 488

2.9 GENERAL

WARM-UP TIME 20 min. 1 year accuracy
1.5h for full rated accuracy

RELATIVE HUMIDITY

up to 25°C max. 75%
above 25°C max. 65%

POWER SUPPLY

Voltage 220 V (110 V, 120 or 240 V
selectable)
Power consumption about 17 VA
Frequency 50/60 Hz

WEIGHT about 3.4 kg

ENCLOSURE Slim line aluminium case

DIMENSIONS

Height without feet about 67.5 mm (2.66 ins)
Height with feet " 84 mm (3.31 ins)
Width " 255 mm (10.04 ins)
Depth " 276 mm (10.87 ins)

3. Commencing Operation

Every P R E M A measuring unit has been carefully tested in detail before leaving the factory, to make sure that its function conforms to all technical specifications. The unit should be in perfect electrical condition on arrival at the customer. To verify this, the unit should be examined for transportation damage immediately on arrival. In the case of grounds for complaint, a protocol of damage found should be drawn up together with the deliverer.

Mains Connection

This P R E M A measuring unit is intended for connection to one of the voltages 110V, 120V, 220V, or 240V, 50/60 Hz AC mains input voltage as power supply. Make sure you have an instrument that corresponds to your power line voltage! Voltage fluctuations of +/- 10% and frequency fluctuations of +/- 4% are tolerated. The power consumption is about 17 VA. A cold equipment mains connector with grounding contact, conforming to DIN, is located on the rear of the unit. The unit is protected by a slow blow 0.1 A (220V, 240V line voltage) or 0.2 A (110V or 120V line voltage) miniature fuse. The rocker switch, which is an integral part of the cold equipment mains connector on the rear of the unit, disconnects the unit from the AC mains voltage.

Grounding

To protect the user against possible electric shock, the case of the unit must be grounded by connecting the mains cable to a suitable power outlet with grounding contact. The case is electrically isolated from the shield and from the two input sockets.

* WARNING *

The optional Scanner 6000/01 is equipped with bistable relays, whose contacts are in arbitrary state when the power supply is switched on or off. Thus it is very important to make quite sure that the unit is switched on or off only when no measuring cables are connected if the signal sources can deliver voltages or currents which exceed the limit values specified in the technical data for this unit (Limiting resistors will normally help). The arbitrary state of the relay contacts at switchon or swithoff time may short circuit measured signals in an uncontrolled manner and without due precautions this might damage your measuring circuit or the scanner.

We expressly point out that we accept no liability for consequential damage. Damage to the relay contacts is also not covered by our warrenty obligations.

4. Keyboard and Integration Setting

The nine element keyboard is double-assigned. All black legend functions are activated by single actuation of the respective key. All blue legend functions are called by first pressing the "2nd" function key and then the respective function key. The LED in the "2nd"-key is always lit too when a blue legend function has been selected, i.e. it is lit together with the LED in the blue legend function key.

The functions direct voltage "Vdc", alternating voltage "Vac", direct current "mAdc", alternating current "mAac" and resistance "Ohm" are selected by pressing the respective key.

Range selection is automatic when the "Auto" key has been pressed, or manual with the range keys (up and down keys). When one of these keys is pressed, the autoranging function is switched off and the active range is switched one step up or down for each keypress.

The fast autoranging function makes a preliminary decision within the first third of the set measuring time, whether the active range is the correct one. If the set range is retained after the preliminary decision (fast autoranging), then two further checks are made after elapse of the complete measuring time:

1. The next higher range is selected if the span limit is reached or exceeded.
2. If less than 8% of the set span is reached, then the next lower range is selected. The next measurement then commences in the new range 100 msec after switchover. When range selection is made via the rear input (see section headed IEEE 488 bus interface, then the range keys on the front panel are disabled. The control unit is electrically isolated from the input.

A brief measurement with reduced accuracy is initiated in response to each keypress and each range change, when autoranging is switched on. The brief measurement takes 200 ms and produces no service request when SRQ is selected in IEC bus operation.

After pressing the "Prg" key, "P1" appears in the display for about 1s. If the "Prg" key is pressed again within the 1s delay time, then "P2" appears, again for 1s. "P1" and "P2" stand for "Program 1" and "Program 2".

If no key is pressed during the 1 second delay time, then the programs are executed.

Program 1: Setting the integration time

Program 2: Switch-on, switch-off of the external trigger facility

The up and down keys are used to set the integration time. The following measuring times are available:

0.1	sec.	100 ms	integration time, display 5 1/2 digit
1 - 5	sec.	1 s	integration time, display 5 1/2 digit
1 - 6	sec.	1 s	integration time, display 6 1/2 digit
10	sec.	10 s	integration time, display 6 1/2 digit

Pressing any other key exits this program and the integration time standing in the display at this instant is taken over for determining the measured values.

Switch-on and switch-off of the external trigger facility is made with the "up" key. The display shows "trig on" or "trig off", after alternate presses of the "up" key. Pressing any other key exits the program and the last displayed status is taken over. If start mode has been chosen, then the actual measured value appears in the display.

The functions of the keys "Cal", "Zero", "IEEE" and "MUX" are described in the corresponding subsections.

5. Numerical Display

The measurement results with decimal point, the negativ sign and error messages are shown on the numerical display of the digital multimeter. Certain operating modes of the multimeter are indicated here too.

The active function and the operating mode are indicated by LEDs in the respective keys.

6. Offset Correction

Zero point displacement (drift) is one possible source of error. Normally this type of error is immediately evident by a display reading differing from Zero when the input is shorted. A zero point correction can be made with the "Zero" key. For this purpose place a short circuit at the "VOhm" input and then press the "Zero" key. The instrument makes a zero point measurement whose duration is determined by the set integration time. With 6 1/2 digit display, the zero point measurement takes 20 seconds in the functions "Vdc", "mAdc", during which time the display shows "null" and the remaining time in seconds until the end of the measurement. With 5 1/2 digit display, the zero point measurement takes 2 seconds and only the text message "null" appears in the display. The keyboard is disabled during the correction measurement. The sequence of the correction measurement differs slightly from the description given above, for the functions "Ohm", "Vac" and "mAac". For these functions the zero point is corrected immediately by continual observation of the measured value. If autoranging was switched on before calling the zero point measurement, then all ranges of one function are corrected in succession for zero point. Now the zero point measurement takes 10 seconds for each 6 1/2 digit display span, and 1 second for each 5 1/2 digit display span. When the measurement duration is 10 seconds, the display shows "null" and the remaining time. When the measuring time is 1 s, only the text message "null" appears in the display. For the current measuring ranges, the zero points are corrected with open-circuit sockets (no short circuit; active current sink circuit!).

No short circuit is placed internally in the multimeter for the offset correction, so that the user can place the short circuit at any desired location in the external circuit, to include external error sources in the compensation. This is particularly important for the 2-wire resistance measuring function. The error due to the finite resistance of the measuring leads can be eliminated by the offset correction.

Deviations up to 1% of the measuring range span can be corrected. If the deviation exceeds this limit, then the message "Error 4" appears in the display and on the IEEE 488 bus, and the old correction value is preserved.

7.0 Error Messages and Self-Test

7.1. Error Messages

The digital multimeter recognizes the following error situations caused by incorrect operation or manual control. They are reported in the main display and via the IEEE 488 bus with the designation "Error" and a code number. The code numbers have the following meanings:

- 1 - Overflow for measurement: The reading exceeds the allowed numerical range
- 4 - Error during offset measurement: The offset present at the input sockets is too large for compensation.
- 5 - Error during calibration:
 1. Nominal value smaller than 5% or greater than 100% of the display span.
 2. Calibration switch on the rear of the unit is set to "MEAS".
- 6 - Error in the IEEE 488 bus interface: The multimeter has received a message string containing more than 30 characters.
- 8 - Error during self-test 2: The redetermined and the old checksum do not agree (lithium battery exhausted).
- 9 - Error during self-test 3 (Error in the program ROMs.)

7.2. Self-Test

The digital multimeter executes an automatic self-test routine on mains power-up. Progress of the individual test routines is indicated in the main display by the message "Contr.". If an error occurs during the self-test, this error is reported by a corresponding error message and the multimeter aborts further execution of the self-test routines. To resume execution of the self-test routines press any key. No voltage greater than 300 V may be present at the input sockets of the multimeter during self-test.

- Contr. 1 initializes the multimeter and checks for correct functioning of the analog section.
- Contr. 2 forms a checksum of the calibration factors stored in the battery backed up RAM and compares this recalculated checksum with the old stored value.
- Contr. 3 forms a checksum for the program ROMs and compares this recalculated checksum with a stored control checksum.

8.0 Operating Instructions

8.1. Operating Instructions for Direct Voltage Measurements Vdc

8.1.1. Connecting the voltage to be measured

Connect the voltage to be measured to the two input sockets marked "V/Ohm" on the front panel. A voltage which is positive at the red socket relative to the black socket gives a positive readout in the display. Make sure that the maximum permitted values of the "LO" input and guard (see section "shielding"), and 500 V direct voltage or peak-peak alternating voltage between guard and case, are not exceeded. This condition must be taken into consideration when selecting polarity for high voltage circuits which are not isolated from the power mains.

8.1.2. Input resistance Vdc

In order to make full use of the excellent linearity of the measuring method, the input resistance for voltage measurement is extremely high in some ranges. For example, this still permits relatively accurate measurements up to ± 2 V when the internal resistance of the measured voltage source is 100 kOhm. In the 20 V, 200 V and 1000 V direct voltage measuring ranges, 100 Ohms internal resistance of the measured voltage source already give an error of 1 digit when using 100 thousand digits resolution. The input resistance, display span and resolution are summarized in the following table for the respective measuring ranges:

Range	Maximum Display span	Input Resistance	Maximum Resolution
0,2 V	.2000000 V	1 GOhm	100 nV
2 V	2.000000 V	1 GOhm	1 μ V
20 V	20.00000 V	10 MOhm	10 μ V
200 V	200.0000 V	10 MOhm	100 μ V
1 000 V 1)	1000.000 V	10 MOhm	1 mV

1) see chapter 9.1 for limitation to 125Vp when equipped with option Scanner 6000/01.

8.1.3. Overload Protection

All ranges are very effectively protected against destruction by voltages much greater than the range end value. The maximum tolerated overloads in this sense are:

$\pm 0.2V, \pm 2V$ ranges: $\pm 1000V$ for 60 sec or
 $\pm 700V$ continuous
 $\pm 20V, \pm 200V, \pm 1000V$ ranges: $\pm 1000V$ continuous

However, bear in mind that heavy overloads in the lower ranges will inevitably cause heat-up of the safety resistors and diodes, so that subsequently thermoelectric EMFs may cause a zero displacement until internal temperature equilibrium has been reestablished.

8.1.4. Common mode suppression

The common mode rejection of a measuring unit is the capability of indicating only the wanted difference signal between the "HI" and "LO" input, with ideally complete suppression of any response to a common voltage which both input terminals may have with respect to ground. Where as an ideal system would give no response to a common mode signal, so that it would show no error due to this cause, in a practical system stray capacitances, finite insulation resistance and resistive circuit asymmetry will convert a portion of the common mode voltage to a series voltage. The common mode rejection factor of this multimeter is better than 140 dB when the resistive asymmetry of the measuring leads has any value up to 1 kOhm.

8.1.5. Shielding

If no problems due to common mode voltage are expected in a given measuring task, then the guard input (blue socket) should be strapped to the "LO" input (black socket) .

A high rejection factor for direct voltage and common mode voltage can be obtained in critical cases by appropriate connection of the guard input. Common mode voltages are voltages which lie between the low point of the voltage to be measured and mains (power) ground, or between power ground of the voltage source and ground potential of the measuring unit. Common mode voltages attempt to send currents in the same direction via both input sockets. For optimum shielding effect, connect the guard input to a direct voltage potential equal to that of the "LO" input such that currents flowing in the shield do not flow through resistances in the voltage source circuit and voltage measuring leads, which could disturb the voltage being measured.

8.2. Operating Instructions for Resistance Measurements $\Omega/k\Omega$

Resistance measurements with this multimeter are made according to the following principle: A load-independent current (I) is passed through the resistance (R_x) which is to be measured. This current also flows via a known internal range resistor. The voltage drop across R_x is measured via the input sockets "V=" and the ratio of this voltage drop to the voltage drop across the internal range resistor is determined. Thus any drift or ageing of the reference voltage source has no effect on the accuracy of the resistance measurements.

The digital multimeter makes resistance measurements in 2-wire circuit. For measuring small resistances too with high accuracy, careful compensation of the measuring lead resistances and of thermoelectric EMFs is required, with the aid of the offset correction facility. For this purpose connect the two measuring leads with their test clips to one side of the resistor to be measured, as shown in fig. 8.1, and then make offset correction by pressing the "Zero" key. This correction compensates for all possible sources of error, such as measuring lead resistance, contact resistance and thermoelectric EMFs at the transitions between different metals. Shielded measuring should be used when measuring large resistances (100 kOhm or greater). Connect the shield to ground potential, to prevent errors due to foreign voltages (mains ripple).

General Comments:

The currents through the resistance to be measured have the following values in the respective ranges:

200 Ohm-, 2 kOhm-ranges	700 μ A
20 kOhm-range	70 μ A
200 kOhm-range	7 μ A
2 MOhm-, 10 MOhm-ranges	0,7 μ A

The polarity of the current flowing through R_x is defined such that the end of R_x which is connected to the upper "HI" socket of the "V/Ohm" input has a negative potential with respect to the other end of R_x .

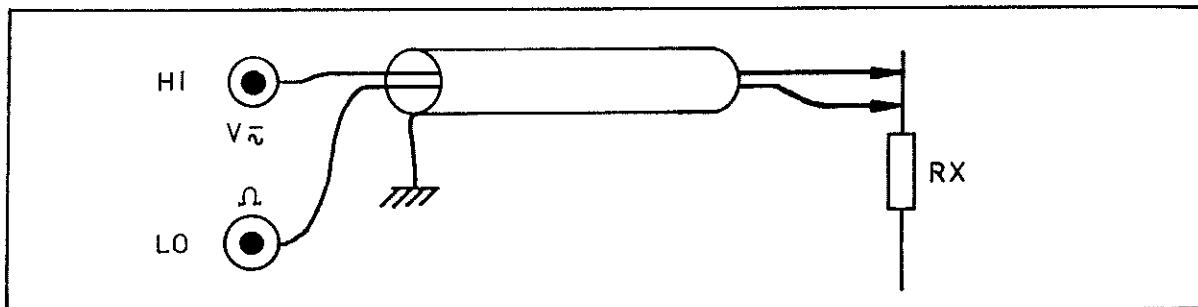

fig. 8.2 Offset correction in Ohm/kOhm Measurement

8.3. Operating Instructions for Alternating Voltage

Measurements Vac

The digital multimeter measures the genuine RMS value of the input voltage, i.e. the RMS value of the applied direct and alternating voltage.

A recommended arrangement for measuring alternating voltages consists of a two-conductor shielded cable with the shield connected to the "guard"-input. For all measurements, the "guard" and the "V/Ohm-LO"-input should be connected to the measuring point which lies closest to ground potential.

Somewhat poorer shielding is achieved by using a single coaxial cable and establishing a link between the "guard" and the "V/Ohm-LO"-input. This often used arrangement is nevertheless satisfactory for most measurements except in very high ambient noise levels and/or when measuring very small voltages.

In the 200 V and 700 V ranges and when measuring alternating voltages with high frequencies (above 100 kHz for the 200 V range or above 10 kHz for the 700 V range), it must be ensured that the applied alternating voltage does not exceed the RMS value product of 10 million VHz.

8.4. Operating Instructions for Measuring Direct Current mA_{dc}

Alternating Current mA_{ac}

Direct and alternating currents can also be measured with this digital multimeter, using the "A ac,dc" input. When connecting-up the measuring circuit, bear in mind that the two black "LO"-sockets of the inputs "V/Ohm" and "A" are connected together internally. Thus it is not possible to connect simultaneously two measuring leads for current measurement and two leads for voltage measurements, if there is a potential difference between the respective measuring points. The internal connection between the "V/Ohm" socket and the "A"- "LO" socket is protected against current overload by a 0.1 A fuse (slow blow). Offset correction by keypres is possible for the current measuring ranges too. But in contrast to all other functions, the offset correction for current measuring ranges must be made with the input sockets open circuit (see also the section headed "offset correction").

A 0.1 Ohm shunt is used in the 2 A range. But in the 2 mA range a current compensation circuit is used which permits load voltages smaller than 1 mV. Autoranging can be activated for the current measuring ranges too. The current measuring ranges are protected by power diodes and an additional quick blow 3 A fuse.

* CAUTION *

Before replacing blown fuses, disconnect the mains plug and all measuring cable plugs, release the central cabinet screw on the base of the instrument and then carefully lift off the top shell of the case. Thereby in the bottom shell of the case, i.e. that they are not pulled out too when lifting the top shell. The two case shells are connected together with a grounding lead which should be disconnected. The 3A (quick blow) fuse is located near the input sockets of the instrument and the 0.1 A (slow blow) fuse is located close to the large blue 0.1 Ohm shunt at the front right inside the instrument (see layout diagram of the preamplifier in Annex).

9. Operating Instructions for Scanner/Multiplexer (Option 6000/01)

As an extra option, the digital multimeter can be equipped with a 10-channel 4-pole multiplexer which has very low thermoelectric EMFs.

When the DMM has been equipped with the scanner option, the maximum permitted voltage at the subminiatur type D 50-pole socket on the rear or at the "V/Ohm"-input sockets, is 125 V peak-peak, with the restriction for the RMS product to be lower than 1 Million VHz.

* WARNING *

The optional Scanner 6000/01 is equipped with bistable relays, whose contacts are in arbitrary state when the power supply is switched on or off. Thus it is very important to make quite sure that the unit is switched on or off only when no measuring cables are connected if the signal sources can deliver voltages or currents which exceed the limit values specified in the technical data for this unit (Limiting resistors will normally help). The arbitrary state of the relay contacts at switch-on or switch-off time may short circuit measured signals in an uncontrolled manner and without due precautions this might damage your measuring circuit or the scanner.

We expressly point out that we accept no liability for consequential damage. Damage to the relay contacts is also not covered by our warranty obligations.

The multiplexer is of type "1 of 10", i.e. one freely selectable channel at a time can be connected through. The inputs are collected on a 50-pole subminiature type D socket connector mounted on the rear of the unit. The 4 output lines of the multiplexer are connected internally to the multimeter input sockets "V/Ohm" and "A". The front sockets too can be switched in and switched-out via the IEEE 488 bus interface. When the front sockets are switched-in, they too are connected to the "V, Ohm" and "A" inputs of the multimeter. The front sockets are in switched-in state immediately after power-up of the digital multimeter. The operating instructions for this function are contained in the section headed "IEEE 488 bus interface". A shield is provided separately for each multiplexer channel and is connected to the "guard" socket on the front of the unit and to pin 1 of the subminiature type D socket connector. An adapter card is also available which plugs onto the subminiature socket connector and provides screw terminal connections for the multiplexer inputs.

Channel selection can be made via the keyboard as well as via the IEEE 488 bus. After pressing the "Mux"-key (first press "2nd" and then press "Mux"), the presently selected channel is shown in the display, e.g. "chn. = 2".

A new channel can now be selected with the range key. The ten channels are numbered consecutively from 0 to 9. Between channels 9 and 0 there is a state with indication "-" in the display, corresponding to the state "multiplexer switched off". To exit this program and connect-through the selected channel, press any other key.

Channel selection is made via the IEEE 488 bus interface using the command "MX" (see section headed "IEEE 488 bus interface").

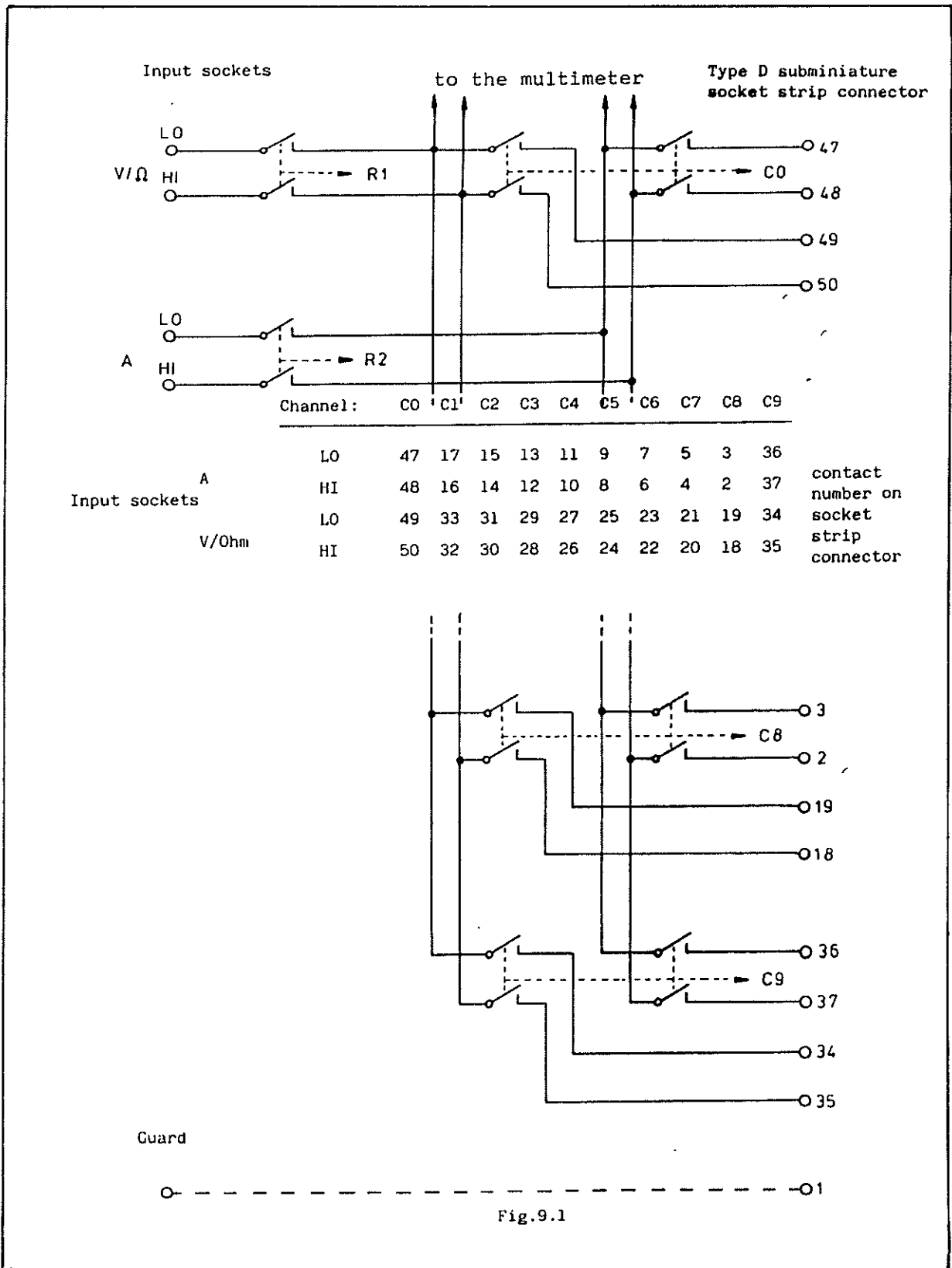

Fig. 9.1. Pin configuration for ten channel scanner (Option 6000/01)

10. EXTERNAL TRIGGERING

The digital multimeter can be triggered for a single measurement via a 3.5 mm post office type jackplug mounted on the rear panel. A second start mode under software control is possible too, via the IEEE 488 bus. Both start modes have the same time sequence.

If program 2 (see the section describing the keyboard) has placed the digital multimeter in "trig on" status, single measurements can be started via the trigger socket. The start time is the rising flank of a trigger pulse with a time jitter not exceeding 25 ms (see Fig. 10.1). Via the IEEE bus, the digital multimeter is placed in start mode by the command "S1". Each further transmission of "S1" then corresponds to a trigger as described above. The digital multimeter can also be started by the addressed command GET (Goup Execute Trigger). The display and the IEEE message are refreshed at the end of the measuring time. If service request is switched on, then the SRQ line is activated. In "TALK ONLY" mode, the digital multimeter sends a message to a connected device in "LISTEN ONLY" mode.

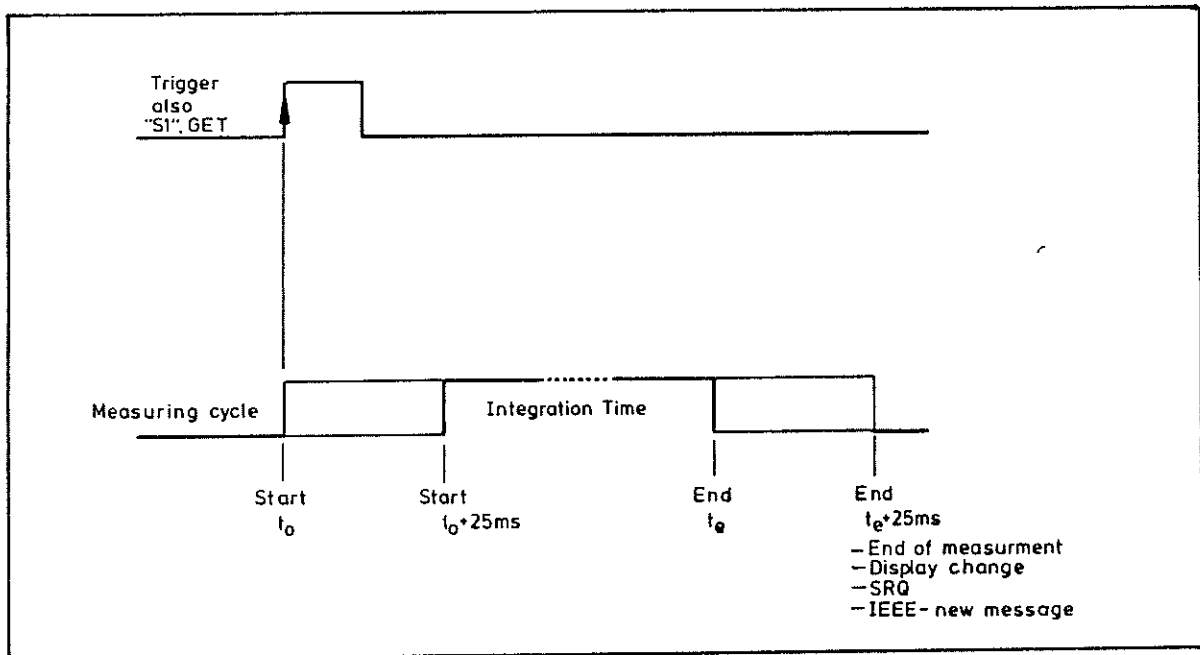

fig.10 timecourse in the triggermode

Range and function switching operations carried out shortly before triggering may lead to delay times of up to 225 ms.

11.0 IEEE 488 - Bus - Interface

Capabilities of the IEEE 488 bus interface

SH1	Handshake source function
AH1	Handshake sink function
T5	Talker function
L3	Listener function
RL1	Remote control
DC1	Reset function
DT1	Trigger function
SR1	Service request function

11.1. Programming the Digital Multimeter via the IEEE 488 bus Interface

Set the device address using the numerical keyset of the digital multimeter. For this purpose, first press the "IEEE"-key . The digital multimeter is then in status "set device address". The display shows the present device address setting, e.g. "IEEE.07.8" which means that the unit is set at present to device address 7 and end character type 8. The digital multimeter is set to this device address and end character as delivered from the factory. The "07" in the display is flashing, to indicate that the device address can now be changed.

Use the "up" key to change the device address. The first actuation of this key starts a cyclic run-through of device addresses from 01 to 30. After address 30 the characters "--" appear in the display for operating status "TALK ONLY". When the desired address or "TALK ONLY" is reached, the process is stopped by pressing the "up" key again. To select the end character by its designation number, press the "down" key. The digit after the decimal point now flashes, indicating that the end character can now be changed. Selection of one of nine possible end characters is made with the "up" key in the same manner as for selecting the device address.

The following terminating characters and terminating character combinations are available :

Designation Number	Terminating Character (Combination)
0	CR + EOI
1	CR
2	LF + EOI
3	LF
4	CR + LF + EOI
5	CR + LF
6	LF + CR + EOI
7	LF + CR
8	EOI

The desired device address including the designation number of the terminating character combination is now present in the display. Press any key except a range key to transfer this address information into working memory and exit the status "set device address". If it is desired to take over these new settings into protected memory, set the calibration switch on the rear of the unit to position "Cal" before takeover of the address data.

```

*****
* DO NOT FORGET TO RETURN THE CALIBRATION SWITCH TO THE *
*                                                                 *
*                               POSITION " M E A S "                *
*****

```

The new device address will now not be lost when the digital multimeter is switched off. The keyboard of the digital multimeter is disabled after the digital multimeter has been accessed once via the IEEE 488 bus interface. The keyboard is enabled again when the "REN" becomes inactive or when the controller transmits the addressed command GTL (go to local).

The "TALK ONLY" capability in conjunction with a printer with "Listen Only" attribute, permits set-up of a self-complete measuring station. After each end of measurement (e.g. after a trigger), the multimeter outputs a measured value with the selected terminating characters to the IEEE bus.

The digital multimeter does not interrupt its continuous measuring sequence within the talker function. The digital multimeter understands the universal commands DCL(Device Clear), SPD(Serial Poll Disable), and SPE(Serial Poll Enable). The command DCL sets the digital multimeter into status "Direct voltage measurement with 1000 V range".

To program the digital multimeter, proceed as follows: Data input is possible as a character string of length 2 to 30 characters, e.g. "VDR3A0M3Q1L1" or "VDR3" or "R3". Every digital multimeter command consists of two characters. The sequence of several commands within one string is arbitrary, with the exception of the command "NV" (see description of this command). The ISO-7-bit code is used for command transfer. Any spaces in the transferred string are ignored. If the digital multimeter receives more than 30 characters (excluding any spaces), then it evaluates the first 30 characters and also reports a transmission error (see section headed "error messages").

11.1.1. Device Messages understood by the digital multimeter

VD	Direct Voltage
VA	Alternating Voltage
O2	Resistance measurement, 2-wire circuit
ID	Direct current
IA	Alternating current
R1	Range 0,2 Vdc, Vac, kOhm,
R2	Range 2 Vdc, Vac, kOhm 2mAdc 2mAac
R3	Range 20 Vdc, Vac, kOhm
R4	Range 200 Vdc, Vac, kOhm
R5	Range 1000 Vdc, Vac, 2000kOhm, 2000mAdc, 2000mAac
R6	Range 10000 12000kOhm
A0	(A/Zero) Autoranging off
A1	Autoranging on
T1	Integration time 100ms; display 5 1/2 digits
T2	Integration time 1 s; display 5 1/2 digits
T3	Integration time 1 s; display 6 1/2 digits
T4	Integration time 10 s; display 6 1/2 digits
Z0	Zero
S1	Start mode, Start
S0	(S/Zero) continuous measuring

M0 Multiplexer switched off
M0 Multiplexer channel 0 selected (M/Zero)
M1 " " 1 "
M2 " " 2 "
M3 " " 3 "
M4 " " 4 "
M5 " " 5 "
M6 " " 6 "
M7 " " 7 "
M8 " " 8 "
M9 " " 9 "

C0 (C/Zero) Front sockets switched-out
C1 Front sockets switched-in

L0 (L/Zero) Digital multimeter transmits only
 measurement result
L1 Digital multimeter transmits measurement and
 programmed status data

Q0 (Q/Zero) without Service Request SRQ
Q1 with Service Request SRQ

NVXXXXXX Nominal value (for calibration)

11.1.2 Description of the device messages

"VD" Selects the measuring function "direct voltage" in the
 digital multimeter.

"VA" Selects the measuring function "alternating voltage".
 The rms value of the alternating voltage with superim-
 posed direct voltage component is measured.

"O2" Selects the "resistance" measuring function. Measure-
 ments are made in 2-wire circuit.

"ID" Selects the "direct current" measuring function.

"IA" Selects the "alternating current" measuring function.
 The rms value of the alternating current with super-
 imposed direct current component is measured.

- "RX" The measuring range within each function is selected with "RX". "X" stands for the designation number of the desired measuring range. Note that some measuring ranges can be selected only in conjunction with a corresponding measuring function, e.g. R6 only for function "kOhm".
- "A0" (A/Zero) switches off autoranging.
- "A1" switches on autoranging.
- "TX" Sets the integration time and the number of digits shown in the display for the measurement result. 6 1/2 digits are always transmitted via the IEEE 488 bus.
- "Z0" Starts an offset correction. The instructions in the section headed "offset correction" are valid.
- "S0" (S/Zero) Starts the continuous measuring sequence.
- "S1" Stops the continuous measuring sequence. The delay until execution of the commands "S0" and "S1" may amount up to 25 msec.
- "MX" Selects a multiplexer channel. "M0" switches off the multiplexer; "M0" (M/Zero) to "M9" select the respective multiplexer channels 0 to 9.
- "C0" (C/Zero) disconnects the front sockets from the multimeter input (effective only when the scanner is fitted)
- "C1" Connects the front sockets to the multimeter input (effective only when the scanner is fitted).
- "L0" (L/Zero) Short format: The multimeter transmits only the first data block (measurement data and text messages).
- "L1" Long format: The multimeter transmits both data blocks (measurement data and text messages in first block and programming data in second block).
- "Q0" (Q/Zero): The multimeter transmits no Service Request SRQ.
- "Q1" The multimeter transmits a Service Request SRQ with:
- each new measurement result
 - each error message
 - reset

"NVXXXXXX" After NV the multimeter expects a 6-digit unsigned decimal integer number as nominal value for calibration via the IEEE 488 bus. A nominal value for calibration must be transmitted alone, i.e. no further command from the table above may be contained in the same string. The digital multimeter commences the calibration measurement after receiving the nominal value

11.2. Device Messages Transmitted from the Multimeter

The device messages transmitted from the multimeter consist of a data set which is generated and transmitted as a block, with end specification. The data set consists of two data blocks. The first data block contains programming status data. Each data block consists of a character string with a fixed number of characters, so that no end character is required or sent between the two data blocks. The first character string contains 12 characters and the second character string contains 16 characters + terminating character(s).

If character transmission from the multimeter is discontinued before the multimeter has gone to TIDS status, transmission commences with the first character of the data set after a new call.

The terminating character(s) of the data set are as chosen according to the section headed "Programming the digital multimeter via the IEEE 488 bus interface".

The ISO-7-bit code is used for transmitting the device messages.

11.2.1 Description of the transmitted data set

The contents of the display are transmitted in the 12 characters of the first data block. These are measurement results and text messages. The measurement results are always transmitted right justified, i.e. termination with the 12th character.

The first character is always the sign, "+" or "-", for direct voltage measurements. All not required leading digits before the measurement result are filled with zero.

No sign is output for resistance, alternating voltage and current measurements and all not required leading digits in front of the measurement result are filled with zero. Measurement results are output in exponential form without spaces.

e.g. +01.9876E+2

The text messages have the format:

"ERR. X", "NULL", "CAL."

These messages are always left justified, i.e. they commence with the first character of the data block. All not required characters are filled with spaces (blanks).

The second data block always commences with the 13th character. This data block outputs the programmed status of the multimeter. Output of the second data block can be enabled or disabled with the digital multimeter command "L1" or "L0" (L/Zero) respectively (see section headed "Programming the digital multimeter via the IEEE bus interface").

11.2.2 Device messages transmitted by the multimeter
(IEC 625 Part 2)

```

1st. character          26.th character
!                      !
+X.XXXXXXE+XVDRXA0TXS0Q0COMXEND
      VA A1 S1Q1C1
      O2
      ID
      IA
(-----)(-----)
1st. data      2nd. data
  block        block

+              Sign of mantissa for VD and ID,
              Zero for VA,O2 and IA

X.XXXXXX      7 digit mantissa

E+X           1-digit exponent with sign

VD,VA,O2,    Measuring function:
ID,IA        VD - Direct voltage
              VA - Alternating voltage
              O2 - Resistance, 2-wire-circuit
              ID - Direct current
              IA - Alternating current

R1-R6        Measuring range:
R1 =  0,2 Vdc,      Vac,      kOhm,  ...  ...
R2 =   2 Vdc,      Vac,      kOhm, 2mAdc, 2mAac
R3 =  20 Vdc,      Vac,      kOhm,  ...  ...
R4 = 200 Vdc,      Vac,      kOhm,  ...  ...
R5 = 1000 Vdc, 700 Vac, 2000 kOhm, 2Adc, 2Aac
R6 = 10000 ...,   ..., 12000 kOhm,  ...  ...

A0, A1       Autoranging (0(Zero) = off, 1 = on)

T1-4         Integration time, number of display digits
T1           100ms           , 5 1/2
T2           1s              , 5 1/2
T3           1s              , 6 1/2
T4           10s             , 6 1/2

S0, S1       Start, Stop
Q0, Q1       SRQ-status (0(Zero)=without, 1=with SRQ)

```

MO, M0-M9 M0(alphabetic 0) = multiplexer is switched off
 M0(M/Zero)-M9 = multiplexer channel 0..9 selected

END Terminating character(s) as selected when
 setting the device address. For terminating
 character No.8, EOI is transmitted together with
 the final (26th.) string character.

11.2.3 Service request function (SR interface function)

The IEEE 488 bus interface of the digital multimeter is equipped with a service request function (SR function, SRQ). The individual status bits transmitted with a service request have the following meanings:

Bit 1: End of measurement
Bit 3: Overflow during measurement
Bit 4: Error messages
Bit 6: Reset
Bit 7: SRQ

Bit 1: end of measurement, can appear together with the other status bits, in order not to falsify the SRQ in the case of fast measurement sequences.

Bit 6: appears with a reset, i.e after power-up or in the case of a strong external source interference event. A reset always takes the multimeter to basic status (DC, 1000V, etc.), so that the control computer must reprogram the multimeter according to section 11.1 after detecting a reset.

11.3. Programming examples for the IEEE 488 bus interface

Before the digital multimeter can be operated via the IEEE 488 bus interface, the device address and the end character(s) must be set as described at the beginning of this section. Address 7 and the end character number 8 (only EOI) are recommended in the following examples for Commodore and Tektronix computers.

COMMODORE CBM 3032

Control of the digital multimeter by the CBM 3032. The CBM 3032 is the controller and the digital multimeter is the listener.

```
CBM 3032: 100 print " your entry please "  
          110 input a$  
          120 open 1,7  
                                     "7" is the device address of  
                                     the digital multimeter  
          130 print 1,a$  
          140 close 1
```

Reading the character string from the digital multimeter with the CBM 3032. The CBM 3032 is the controller, the digital multimeter is the talker.

```
CBM 3032: 200 open 2,7  
                                     "7" is the device address of  
                                     the digital multimeter  
          210 input 2,b$  
          220 close 2  
          230 print b$  
          240 goto 100
```

TEKTRONIX 4051: *

Control of the digital multimeter with the Tektronix 4051:
The Tektronix 4051 is the controller, the digital multimeter
is the listener

```
4051: 100 PRI " YOUR ENTRY PLEASE "
      110 INP A$
      120 PRI @ 7:A$
```

"7" is the device address of
the digital multimeter

```
130 GO TO 100
```

Reading the character string from the digital multimeter by
the Tektronix 4051. The Tektronix 4051 is the controller, the
digital multimeter is the talker.

```
4051: 140 INP @ 7:B$
```

"7" is the device address of
the digital multimeter

```
150 PRI B$
160 GO TO 100
```

HEWLETT PACKARD HP 85 *

The device address of the multimeter is 7, the end character
is No.5 (CR+LF without EOI).

Control of the digital multimeter by the HP 85. The HP 85 is
the controller and the digital multimeter is the listener.

```
HP 85 : 130 PRINT " YOUR ENTRY PLEASE "
      140 INPUT B$
      160 OUTPUT 707;B$
      190 END
```

Reading the character string from the digital multimeter with
the HP 85. The HP 85 is the controller, the digital multimeter
is the talker.

```
HP 85 : 530 DIM A$ [50] string size agreement ;choose large
      enough, at least 29 characters
      550 ENTER 707;A$
      580 DISP A$
      590 END
```

HEWLETT PACKARD HP 87 *

The device address of the multimeter is 7, the end character is No.5 (CR+LF without EOI).

HP 87 : 10 DIM A\$ [40] , B\$ [30]

string size agreement, chose large enough, at least 29 characters

Control of the digital multimeter by the HP 87. The HP 87 is the controller and the digital multimeter is the listener

20 INPUT B\$

entry via HP 87 keyboard (voltmeter code), up to 30 characters

30 OUTPUT 707;B\$

string transfer from the HP 87 to the digital multimeter

Reading the character string from the digital multimeter with the HP 87. The HP 87 is the controller, the digital multimeter is the talker.

40 ENTER 707;A\$

string transfer from digital multimeter to the HP 87 (26-28 characters)

50 PRINT A\$

60 GOTO 20

HEWLETT PACKARD HP 87 *

Operation of the digital multimeter as before, but now with SRQ.

The device address of the multimeter is 7, the end character is No.5 (CR+LF without EOI).

```

HP 87 : 10 ON INTR 7 GOSUB 500
        checks IRQ from IEEE 488 bus
        20 DIM A$ [30], B$ [40]
        string size agreement, choose
        large enough, at least 29 charac-
        ters
        30 INPUT B$
        entry via HP 87 keyboard , e.g.:
        "Q1" for SRQ enabled
        40 OUTPUT 707;B$
        string transfer from the HP 87 to
        the digital multimeter
        50 ENABLE INTR 7;8
        enable IRQ initiated by SRQ
        60 GOTO .....
        line number of user program

500 STATUS 7,1; W
510 P=SPOLL (707)
        transfer of the SRQ status register
520 IF P> 63 THEN GOSUB 1000
        evaluation of the register contents
530 ENABLE INTR 7,8
        enable IRQ initiated by SRQ
540 RETURN

1000 ENTER 707;A$
        read in the message from the
        digital multimeter
1010 PRINT A$, P, "DEVICE NO.7"
        and print it on the screen to-
        gether with status information
1020 RETURN

```

HP 9816 (200 Series)

```
-----
1000 !***** Data transmission HP 9816 *****
1010 !
1020 !Declaration of variables
1030 !
1040 COM / DMM 5000/ @ Dmmnr, Setup$ [30] , DISPLAY$ [30]
1050 !
1060 ! Adress assignment -- 7 = @ Dmmnr
1070 !
1080 ASSIGN @ Dmmnr TO 707
1085 ON INTR 7,1 CALL Serialpoll
1090 !
1100 READING THE DESIRED SETUP VIA THE KEYBOARD
1110 !
1120 INPUT Setup$
1130 OUTPUT @ Dmmnr ; Setup$
1140 !
1150 ! ENABLE INTERRUPT
1160 !
1170 ENABLE INTR 7;2 !IRQ by appearence of an SRQ-signal
1180 Haupt: !
1190 GOTO Haupt
1200 END
1210 !.....
1220 !.....
1230 SUB Serialpoll
1240 ! CHECKS DEVICE FOR SERVICE REQUEST, READS IF REQUIRED
1250 ! AND RETURNS TO THE WAITING LOOP OF THE MAIN PROGRAM
1260 !
1270 !
1280 COM /Dmm5000/ @ Dmmnr, Setup$ [30], DISPLAY$ [30], P
1290 !
1300 P=SPOLL ( @ Dmmnr)
1310 !
1320 IF P>63 THEN CALL Measval
1330 ENABLE INTR 7
1340 SUBEND
1350 !.....
1360 !.....
1370 SUB Measval
1380 !.....
1390 !READS IN THE PRESENT MEASURED VALUE FROM THE VOLTMETER
1400 !.....
1410 COM/Dmm5000/ @ Dmmnr, Setup$ [30], DISPLAY$ [30],P
1420 ENTER @ Dmmnr; DISPLAY$
1430 PRINT DISPLAY$,P
1440 SUBEND
```

APPLE II with CCS Interface Module 7490 *

```

-----
2 PRINT
3 PRINT "SET DMM 5000 TO ADDRESS 07.0 ."
5 PRINT
6 PRINT "WHEN YOU HAVE DONE SO,"
7 PRINT "PRESS THE RETURN KEY."
8 INPUT C$
10 DIM A$(30), B$(30)
                                dimension the string arrays sufficiently large
12 PRINT:PRINT
15 PRINT "YOUR ENTRY PLEASE:"
20 INPUT B$
30 PR #3

                                initialize slot 3 for output
40 PRINT "@`:"
                                @ switches to address mode;
                                REN and ATN active;
                                ` transmits listener address 7;
                                : switches back to Command mode;
50 PRINT "'";B$;"`"
                                the message is transmitted;
                                ` switches text mode on and off;
60 PRINT " @ G:"
                                @ switches to address mode;
                                G transmits talker address 7;
                                : switches back to Command mode;
70 PR #
                                data from IEEE bus are printed directly
                                on the screen
80 INPUT " ";A$
                                read-in the message from the IEEE bus
90 IN #
100 GOTO 20

```

Lines 20 to 100 are essential.

Lines 2 to 15 are optional for user guidance.

IBM Computer or compatibles with National Instruments inter-
face PC2A

```

1000 CLEAR ,50000!          ' BASIC Declarations
1010 IBINIT1 = 50000!
1020 IBINIT2 = IBINIT1 + 3
1030 BLOAD "bib.m",IBINIT1
1040 CALL IBINIT1(IBFIND,IBTRG,IBCLR,IBPCT,IBSIC,IBLOC,IBPPC,IBBNA,
IBONL,IBRSC,IB SRE,IBRSV,IBPAD,IBSAD,IBIST,IBDMA,IBEOS,IBTMO,IBEOT,
IBRDF,IBWRTF)
1050 CALL IBINIT2(IBGTS,IBCAC,IBWAIT,IBPOKE,IBWRT,IBWRTA,IBCMD,
IBCMDA,IBRD,IBRDA, IBSTOP,IBRPP,IBRSP,IBDIAG,IBXTRC,IBRDI,IBWRTI,
IBRDIA,IBWRITA,IBSTA%,IBERR%,IBCNT%)
1060 REM
1070 PRINT " --- MULTIMETER CONTROL SOFTWARE ---"
1080 PRINT
1090     CMD$ = SPACE$(30)
1100     WRT$ = SPACE$(30)
1110     RD$ = SPACE$(40)
1120     EOS$ = CHR$(13)
1130 REM --- LOOKING FOR THE DEVICE ---
1140 PRINT"DEVICE NAME IS DEV1, DEVICE ADDRESS SEE AT IBCONF.EXE "
1150 PRINT"SET THE DEVICES ADDRESS TO CORRECT VALUE (IEEE 01.0)"
1160 PRINT"VALUE MUST ALWAYS HAVE BEEN INSTALLED IN IBCONF.EXE "
1170 PRINT:PRINT:PRINT:PRINT
1180 PRINT "** Check correct address/terminator combination **"
1190 PRINT "** in IBCONF.EXE is selected **"
1200 PRINT
1210 REM
1220 REM --- DETERMINATION OF ADDRESS ---
1230 REM -----
1240     BDNAME$ = "DEV1":CALL IBFIND (BDNAME$,DEV1%)
1242 REM -----
1250 PRINT "INPUT OF A COMMAND, SENDING TO THE MULTIMETER "
1254 PRINT "REFER TO CHAPTER 11, IEEE COMMANDS i.e. VD,VA,T1, .."
1256 PRINT "A <RETURN> FORCES READING OF DEVICE MESSAGE"
1260 LINE INPUT CMD$
1261 PRINT CHR$(12);CMD$
1262 IF CMD$="" THEN 1268
1264 GOSUB 1280:REM SEND COMMAND
1265 FOR I=1 TO 1000:NEXT I: REM WAIT APPROX. 1 SEC
1268 GOSUB 1340:REM READ MESSAGE
1269 GOTO 1250
1270 REM -----

```

(continued)

Subroutines for output of commands and reading of messages

```
1270 REM --- -----  
1280 REM --- OUTPUT OF COMMANDS TO THE MULTIMETER ---  
1290 WRT$=CMD$+EOS$:REM COMMAND + TERMINATOR (EOS)  
1300 CALL IBWRT (DEV1%,WRT$)  
1310 RETURN  
1320 REM --- OUTPUT OF COMMANDS TO THE MULTIMETER ---  
1330 REM -----  
1340 REM --- READING OF DEVICE MESSAGES FROM THE MULTIMETER ---  
1350 CALL IBRD (DEV1%,RD$)  
1360 MW=VAL(RD$)  
1370 PRINT RD$;MW  
1380 RD$=SPACE$(40)  
1390 RETURN  
1400 REM --- READING OF DEVICE MESSAGES FROM THE MULTIMETER ---  
1410 REM -----
```

Lines 1000 to 1060 and lines 1270 to 1410 are individual for use of the NI-PC2A interface. For different interfaces use their special syntax.

12. CALIBRATION

Allow a period of 2-3 hours to elapse after switching on, before commencing calibration, so that the digital multimeter has reached thermal equilibrium.

The digital multimeter has a digital calibration facility which permits individual range or complete recalibration. It is not necessary to open the unit for recalibration. Recalibration is possible under front panel keyboard control or via the IEEE 488 bus. The correction values from the first calibration carried out in the PREMA factory are stored in the programmable EPROM and in a CMOS RAM with a lithium battery as backup power supply. The multimeter normally uses the correction values which are stored in the CMOS RAM. The service life of the battery is about 10 years. To prevent unintentional destruction of the correction values, they are protected in memory by setting a recessed sliding switch S2 which is located in the middle on the rear of the unit. The settings of this switch are marked "MEAS" and "CAL". To recalibrate the digital multimeter, move the switch S2 with the aid of a small screwdriver or similar tool from "MEAS" to "CAL".

The "CAL" operating mode is indicated by periodic appearance of the legend "CAL" in the main display. In this status the correction values stored in the CMOS RAM are unprotected and can be overwritten. If correction values have been lost accidentally by improper calibration attempts and recalibration is not possible because no calibration standards are available, then the correction values which have been stored by PREMA in the program EPROM at the time of initial calibration of the instrument, can be copied into the CMOS RAM. For this purpose, set the mains switch of the multimeter once to "OFF" and then to "ON" again, whereby the calibration switch on the rear side of the instrument must be left in setting "CAL". Hereby the calibration correction factors are automatically copied from the EPROM to the battery backed-up CMOS RAM and all correction values for the input offset are cleared. Thus it is necessary thereafter to make new compensation of the input offset for all functions and ranges.

For this purpose, place a short circuit at the input sockets V/Ohm" of the digital multimeter, select measuring function "Vdc" and "Auto" for autoranging and then press the "Zero" key. The multimeter now corrects all Vdc measuring ranges in automatic succession and places the found correction values in the RAM which can subsequently be protected. To correct a single measuring range, select just this range, leaving autoranging ("Auto") switched off. Proceed in the same manner for the other functions too (observe the instructions given in sections 12.1 to 12.4).

12.1. Calibrating the Direct Voltage Measuring ranges

First select the measuring range which is to be calibrated and then connect an exactly known positive or negative reference voltage to the input sockets. This reference voltage should not be less than 5% or more than 100% (preferably 50% to 100%) of the range span. The multimeter now displays a measurement result which has been calculated using the old calibration factor. If this actual value differs unacceptably from the nominal value (known value of the reference voltage), then call the calibration program by first pressing the "2nd" function key and then the "Cal" key. The nominal value can now be set using the "up" and "down" keys.

The "down" advances the digit opened for correction. When the digit to be corrected in the display has been reached, it starts counting cyclically 0-9 after a short delay. This counting can be stopped and started again with the "up" key. When all digits have been corrected to the nominal value, start the actual calibration measurement by pressing the "Cal" key (without first pressing the "2nd" function key). "CAL." thereupon appears in the display and the remaining time of the calibration measurement is counted down to Zero in the display, similar to the sequence of events for a Zero point measurement.

There after the unit exits the calibration program and new functions and ranges can be selected. The calibration program is also aborted when any other key except "up", "down" or "Cal" is pressed, in which case the old calibration factor is retained and no change has been made. To recalibrate several measuring ranges individually, start the entire procedure as described above for each range. After completing all intended recalibrations, make quite sure that the recessed switch S2 on the rear panel of the unit is returned from "Cal" to "Meas", so that the calibration data are protected again.

Calibration procedure via the IEEE 488 bus is basically analogous to the described procedure via the front panel keyboard. The nominal value is set as integer number with the command "NVXXXXXX" (see calibration program in the section headed "IEEE 488 bus interface"). The calibration program and the calibration measurement are started automatically on transmission of the nominal value. When no further ranges and functions are to be calibrated, terminate the calibration procedure by returning the switch S2 on the rear panel of the unit from setting "Cal" to setting "Meas".

12.2. Calibrating the Resistance Measuring Ranges

The resistance measuring ranges are calibrated in 2-pole circuit. First connect the zero point by the procedure described in section 12.1. Also observe the instructions given in the section headed "operating instructions for resistance measurements Ohm/kOhm", in particular regarding compensation of the measuring leads resistance. Calibration procedure for the resistance measuring ranges is otherwise analogous to calibration of the direct voltage measuring ranges.

12.3. Calibrating the Alternating Voltage Measuring Ranges

The alternating voltage measuring ranges should be calibrated with a sinusoidal alternating voltage. For the function Vac too, the zero point must first be compensated in function setting Vac, otherwise as described in section 12.1. 1kHz sinusoidal reference voltages are required. The calibration procedure is analogous to calibration of the direct voltage measuring ranges.

12.4 Calibration of the DC and AC Current Measuring Ranges

For the current measuring ranges too, make the same calibration preparations as specified in section 12.1. The zero point measurement must be made with open circuit input sockets (no short circuit). Do not leave any measuring cables connected to the input sockets for the zero point measurement (see also operating instructions for mAdc and mAac). 1kHz sinusoidal reference currents are required for calibrating alternating current measuring ranges. The calibration current (reference current) must not be greater than 1 A in the 2 A range. The calibration procedure is analogous to calibration of the direct voltage measuring ranges.

```
*****
* DO NOT FORGET TO RETURN THE CALIBRATION SWITCH TO THE *
*                                                                 *
*                POSITION          " M E A S "                *
*****
```

13.0. Setting-Up a Self-Sufficient System for Automatic Acquisition of Measurement Data

13.1. Description of the Measuring Set-Up

A small data acquisition system for 20 channels (4-pole) which operates on its own without computer control, can be set up with the PREMA Digital Multimeter 5000 as triggerable multimeter and the PREMA Scanner 2024 as 20 channel scanner. For documentation of the measurements data, a printer with IEEE bus interface (e.g. Epson RX 80 with Interface 8165) (operation mode "LISTEN ONLY") can be connected to the multimeter (operating mode "TALK ONLY").

The Scanner 2024 and the Digital Multimeter 5000 are connected with the trigger cable via the rear panel trigger sockets, and the front panel sockets of the instruments are connected up with the appropriate measuring cables (V/Ohm, A and A, B, C, D).

Connect the 20 channel to the Scanner 2024 via the subminiature type D sockets on the rear panel. Only one function, i.e. voltage, current or resistance, can be measured automatically. The chosen function must be set on the multimeter before starting the measuring run. Fixed ranges can be preset, or the autoranging function of the multimeter may be used.

The measuring channels, measuring times and switching intervals are determined by the scanner. The scanner outputs a trigger signal during the switch-on time of each channel, to cause the multimeter outputs the result to the connected printer.

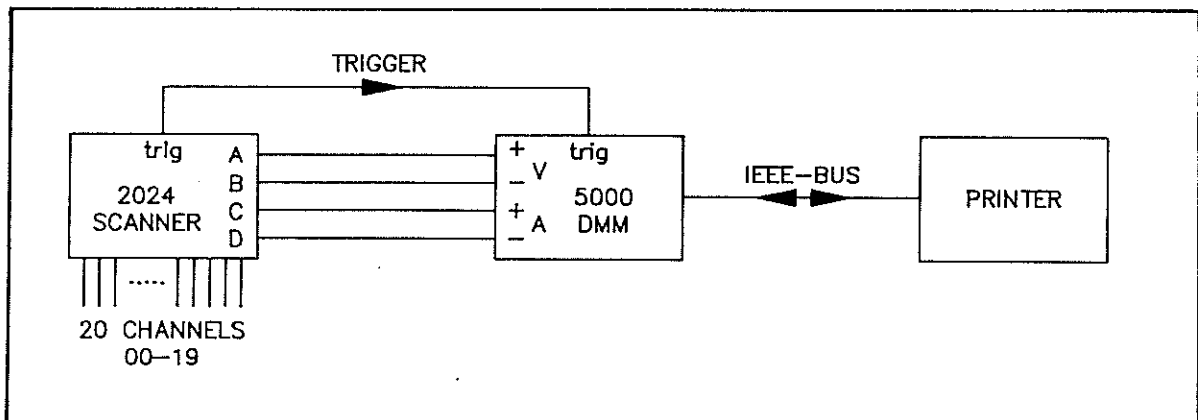

Fig. 13.1. Data acquisition system

13.2. Example of a Measuring Sequence

For example, the channels CH 10 - CH 19 are to be measured automatically every 10 minutes with a channel switch-on duration of 15 seconds for each channel. The results of the measurements are to be output to a printer.

13.2.1. Settings of the Scanner 2024 and the Multimeter 5000

Preselect the channels CH 10 - CH 19 on the Scanner 2024. Set the scan cycle time to 10 minutes, the channel switch-on duration to 154 seconds and the trigger delay time to 2 seconds. The IEEE setting must be "AUTO" (between 00 and 30) (this activates the trigger output). The front panel sockets A, B, C, D of the scanner must be connected (CONTROL).

On the Multimeter 5000, set the integration time to 10 seconds, for example. The IEEE setting must be "TALK ONLY" and choose CR+LF (5) as terminator. Switch to triggered mode. The autoranging function may be switched on to obtain maximum resolution for all values.

Connect the printer ("LISTEN ONLY") to the IEEE bus connector of the multimeter.

13.2.2. Starting the Measuring System

Start and stop the measuring system via the scanner in Automatic Single Scan mode.

After start, channel CH 10 is connected through and after a delay time of 2 seconds the Scanner 2024 outputs a trigger pulse which starts the measurement by the multimeter. After elapse of the 10 second integration time, the multimeter outputs the measurement result data to the printer, together with the status information for function, range, etc. After expiry of the channel switch-on duration of 15 seconds, channel CH 10 is disconnected and channel CH 11 is now connected. After the last channel (CH 19) has been disconnected again after measurement, the end of the 10 minute scan cycle time is awaited and then a new measuring cycle is started. The measuring sequence can be stopped or aborted at any time.

13.2.3. Output to a Computer

When the multimeter is set to a device address instead of "TALK ONLY" and the proper terminator for the computer is selected and SRQ mode is chosen, then a SRQ (Service Request) is issued at the end of each measurement. The computer is connected in place of the printer and reads the measurement result on receiving the SRQ. The computer need not perform any control functions; it can be used purely for data collection.

The settings of the other device parameters for the scanner and for the multimeter can be retained.

14.0. ACCESSORIES

14.1. Mating Plug for Sub-D (Option 6000/03)

For connecting the measuring lines to the scanner, a 50-pole subminiature type D plug can be used for each group of 10 channels. This plug connector has soldered connections and a cable outlet for round cables having up to 12 mm diameter. One plug is required for connecting all 10 channels.

14.2. Adapter Card (Option 6000/02)

One adapter card can be plugged externally onto the 50-pole subminiature type D socket of the DMM 5000, for connecting the measuring lines at screw terminals. The adapter card is also fitted with two antiparallel 3A clamp diodes for each current path, (see circuit diagram of adapter card). These clamp diodes may be removed for other applications, especially when switching currents greater 0.5A-peak shall be switched (diode forward voltage drop!). One adapter card is required for connecting all 10 channels.

Maximum current	1 A
Maximum voltage	40 V

* WARNING *

Safety considerations require that no voltages greater than 40 V with respect to ground may be connected, because the screw terminals are not protected against accidental human contact entailing danger of electric shock.

Dimensions	about 115 x 123 mm/4.5 x
4.8 in	

14.3. Rack Mounting Kit (Option 6000/04)

A complete kit is available for mounting a DMM 5000 in a 19" equipment rack.

Height	2 HU
--------	------

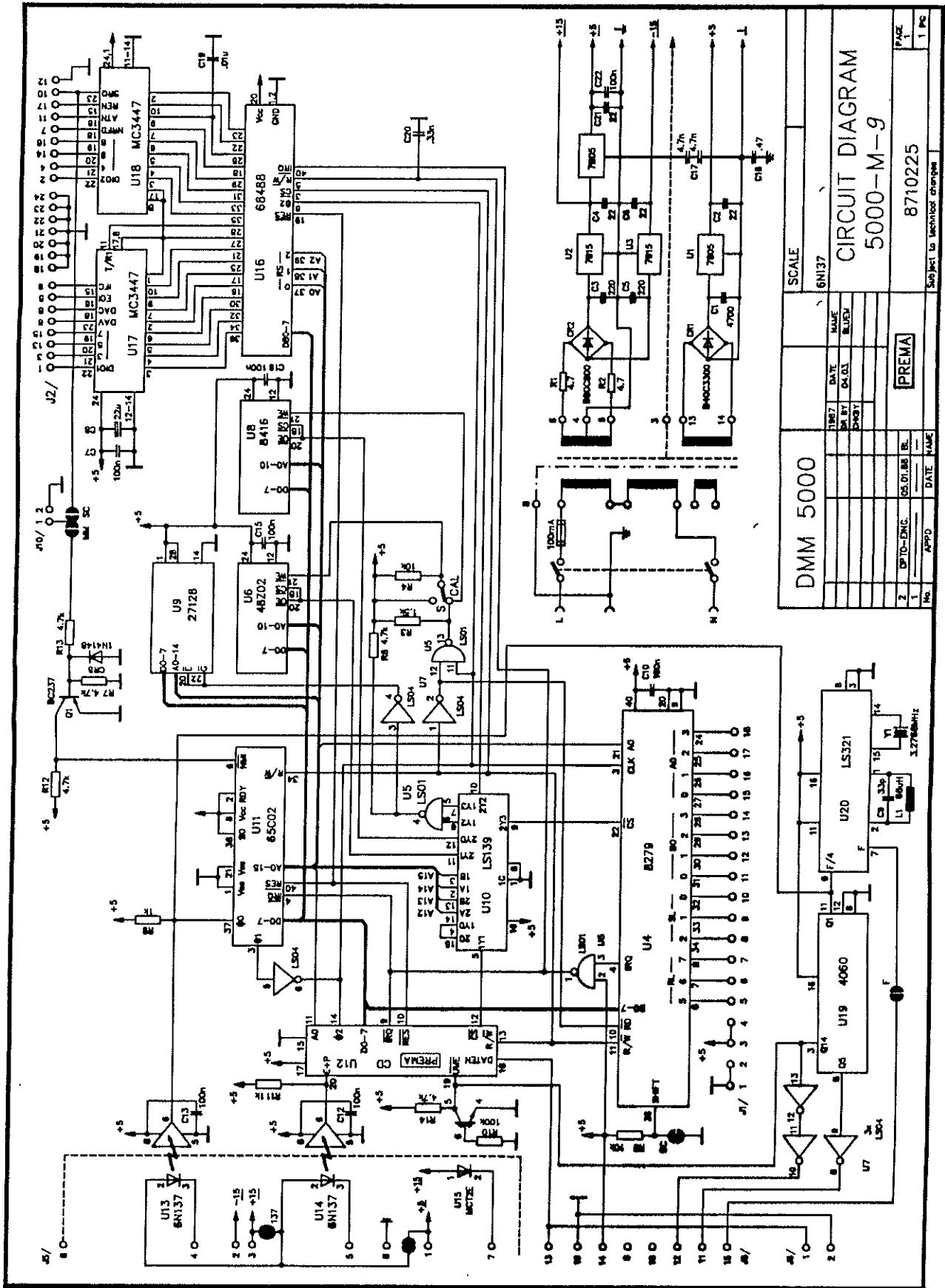

DMM 5000		SCALE	6N137
REV	DATE	NAME	
1	05/01/88	BL	
2	05/01/88	BL	
APPROVED		DATE	NAME
PREMA			
CIRCUIT DIAGRAM		8710225	
5000-M-9		Subject to technical changes	
PAGE	1 of 1		

fig. 15.2 Circuit diagram of the microprocessor

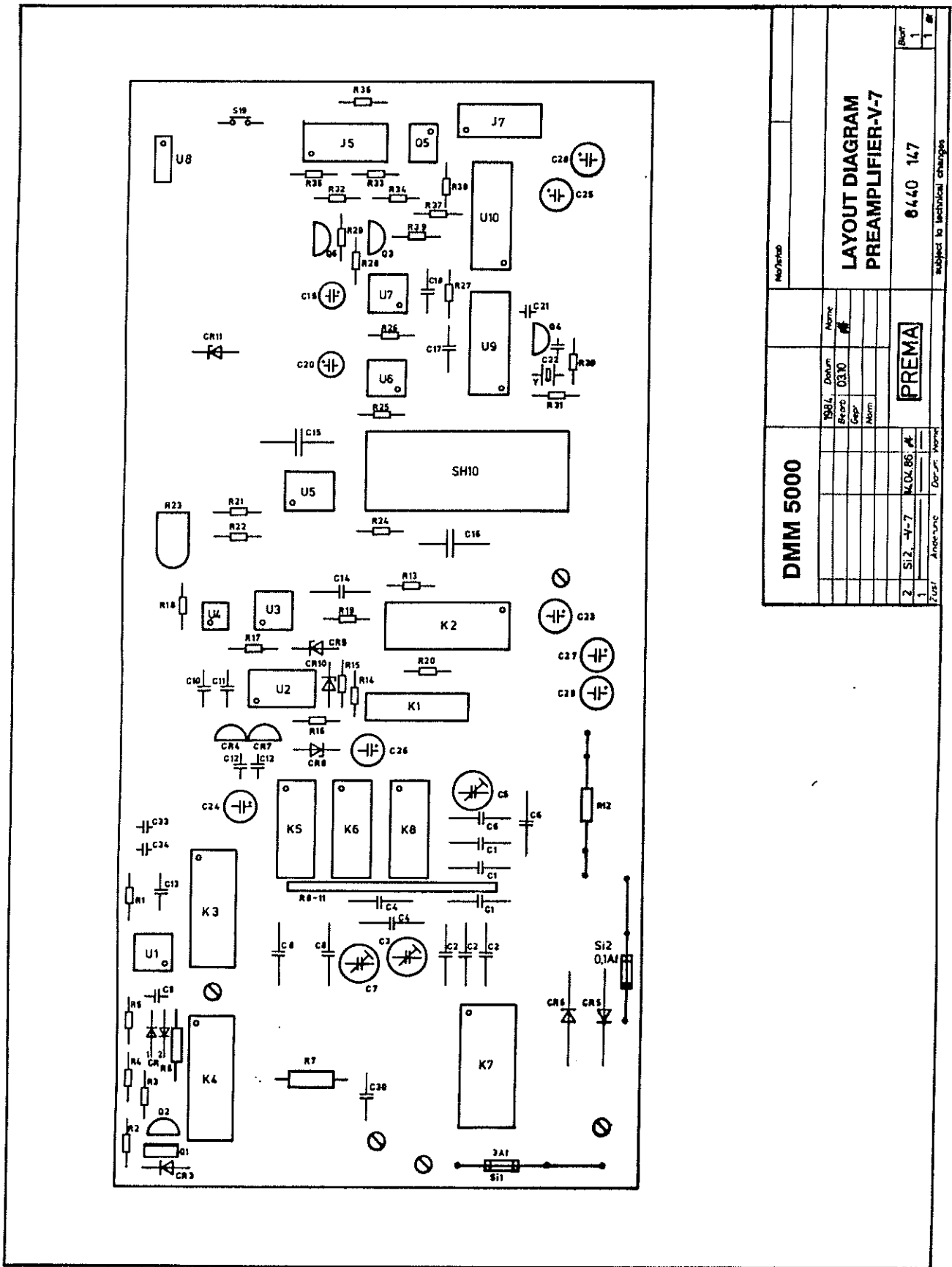

<p>DMM 5000</p>		<p>Model</p>		<p>Rev</p>	
		<p>1984</p>	<p>0310</p>	<p>1</p>	<p>1</p>
<p>LAYOUT DIAGRAM PREAMPLIFIER-V-7</p>		<p>Part</p>		<p>Sheet</p>	
		<p>PREMA</p>	<p>6440</p>	<p>147</p>	<p>1</p>
<p>2 S12-V-7</p>		<p>100486</p>		<p>subject to technical changes</p>	
<p>1</p>	<p>1</p>	<p>1</p>	<p>1</p>	<p>1</p>	<p>1</p>

Fig. 15.3 Layout diagram of the preamplifier

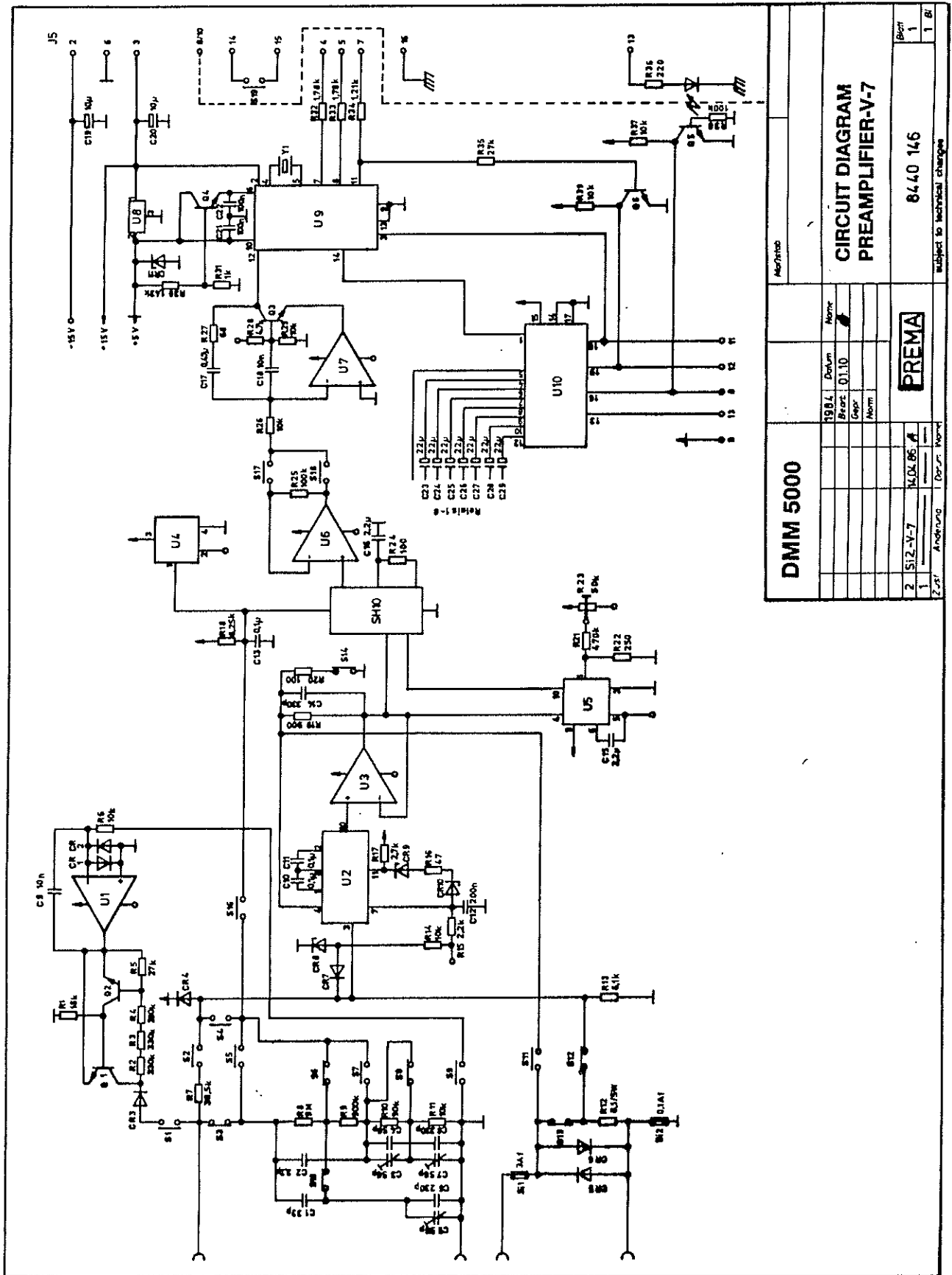
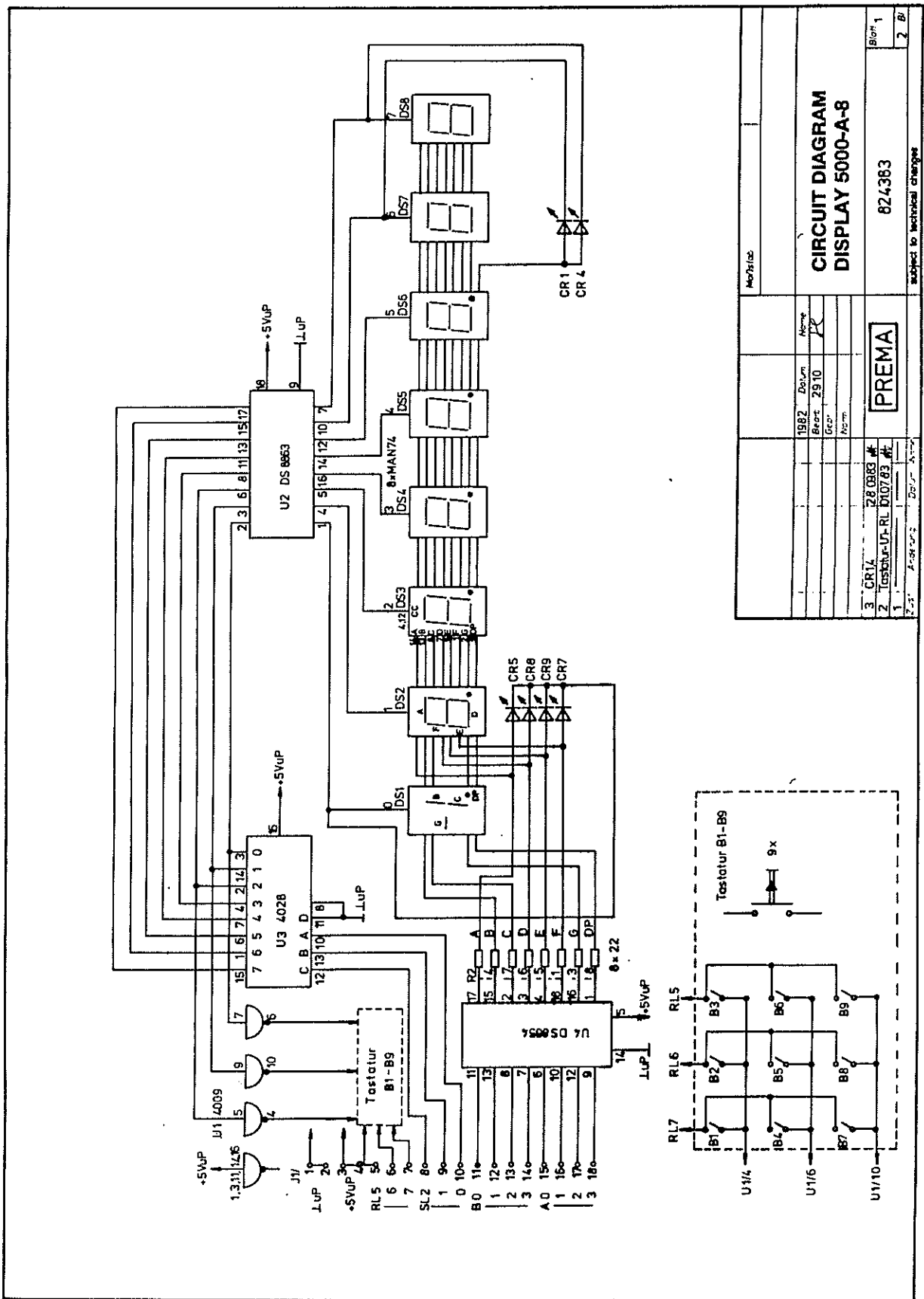

Fig. 15.4 Circuit diagram of the preamplifier

DMM 5000		1984 Datum Norm	
		Bezeichnung: 01.10	Norm
		Gepr.	Norm
		Änderung	Datum Norm
1	2	512-V-7	14.04.86
		PREMA	
		8440 145	
		subject to technical changes	
		Blatt 1	
		1 Bl.	



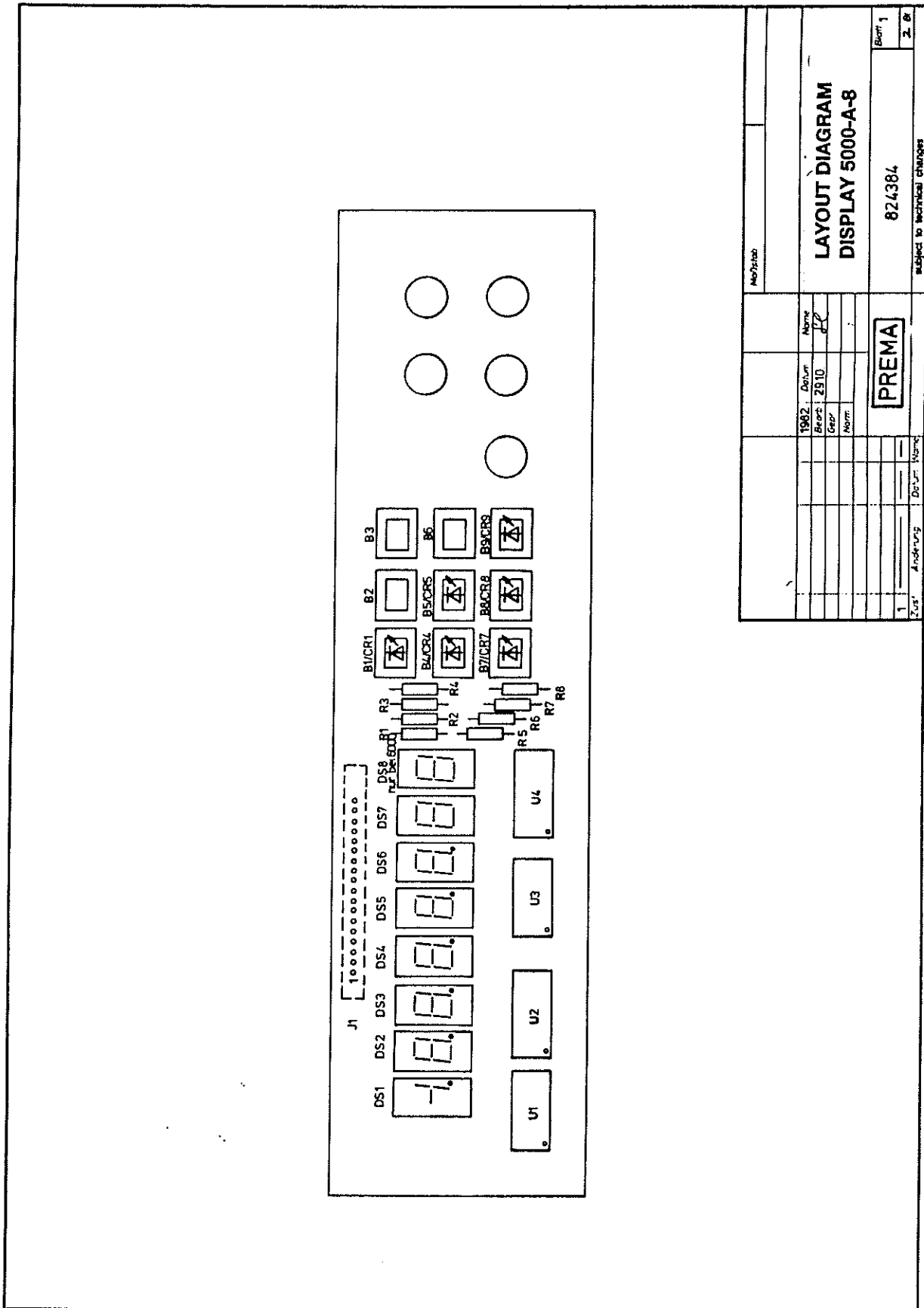
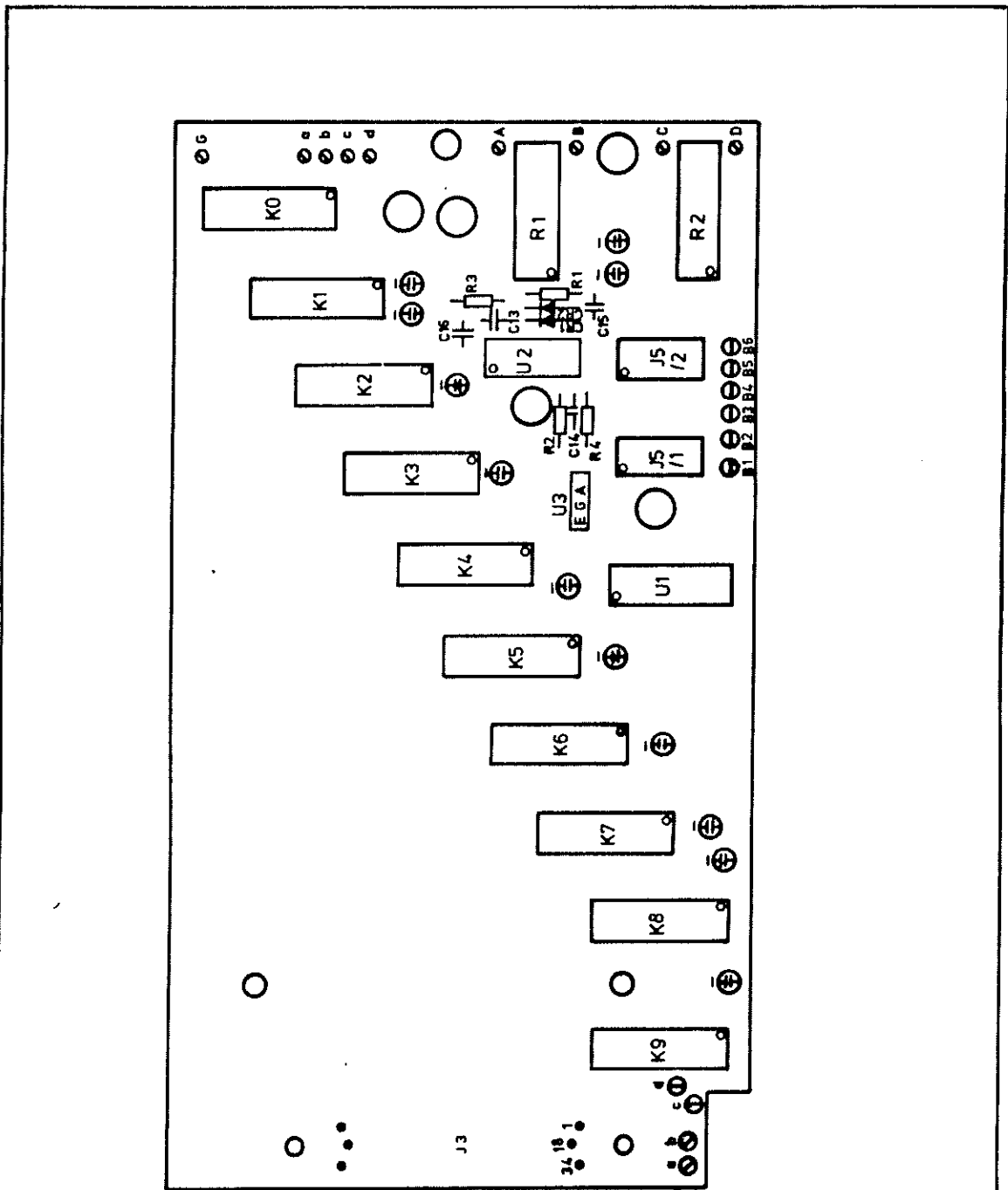
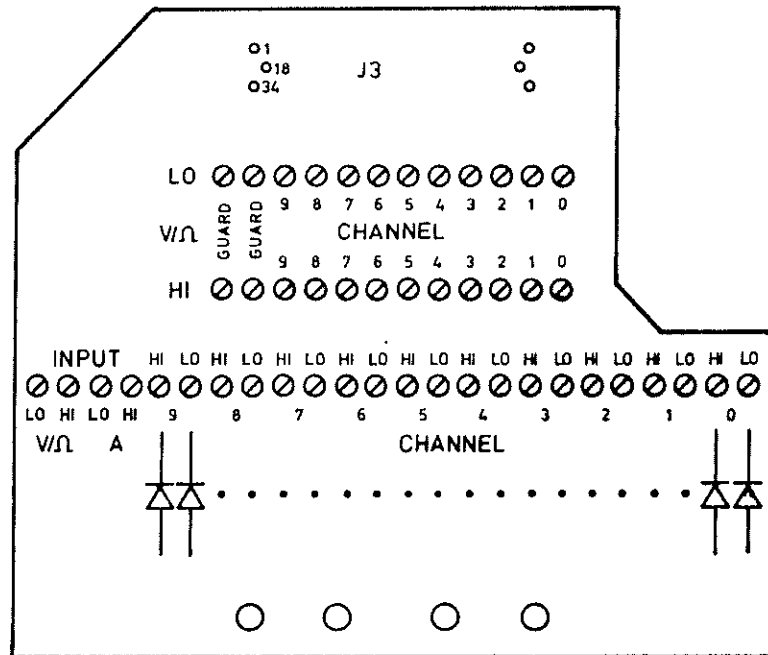

Fig. 15.6 Circuit diagram of the display



				Maßstab 1:1		
				LAYOUT DIAGRAM OF SCANNER 6000/01-8		
	1985	Datum	Name			
	Bearb	19.08				
	Gepr					
	Norm					
				<div style="border: 1px solid black; padding: 2px; display: inline-block;">PREMA</div>		
2-LS,-7,Stammf.		14.04.86		8534 169		
1				Blatt 1 BI		
Zust	Aenderung	Datum	Name	Subject to technical changes		

Fig. 15.7 Layout diagram of the scanner (option 6000/01)



				Maßstab 1:1	
				LAYOUT DIAGRAM OF ADAPTER CARD FOR SCANNER INPUT 6000/02	
	1984	Datum	Name		
	Bearb	19.09	glt		
	Gepr				
	Norm			8438 142	
PREMA					
1				Blatt 1	
Zust	Aenderung	Datum	Name	1 Bl	

Fig. 15.9 Layout diagram of the adaptercard

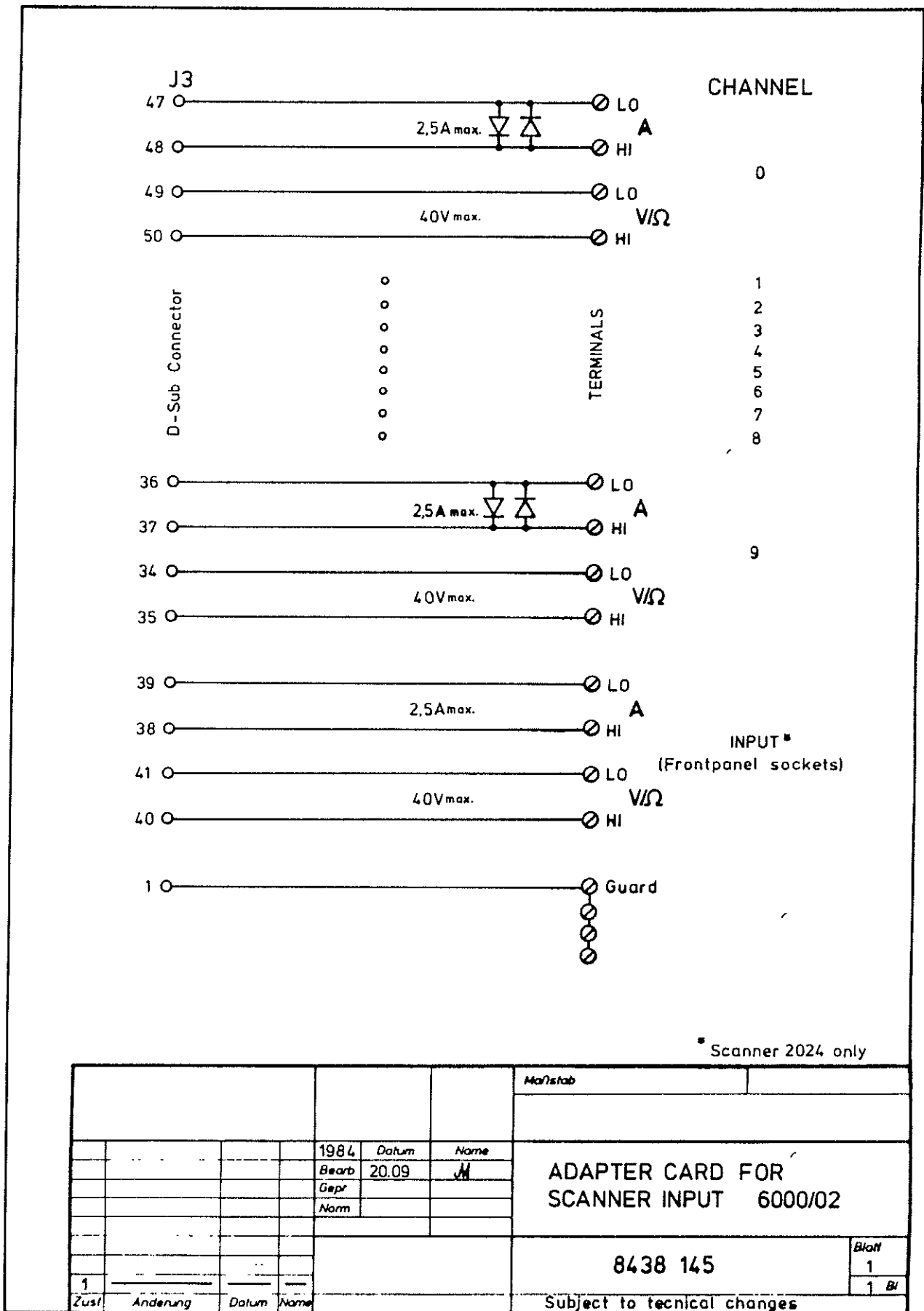

Fig. 15.10 Circuit diagram of the adaptercard

WARNING!



I/O terminals are sensitive to electrostatic voltage (especially the IEEE connector).

It can damage your instrument!



OBSERVE PRECAUTIONS FOR HANDLING

Never touch input plugs or terminals without precautionary measures!

Damage caused by electrostatic voltage is not covered by warranty!