

FIRST WATT B1 PREAMP WITH KORG TRIODE

The original circuit as suggested in the technical data provided was very suitable, and I made only small adjustments to it:

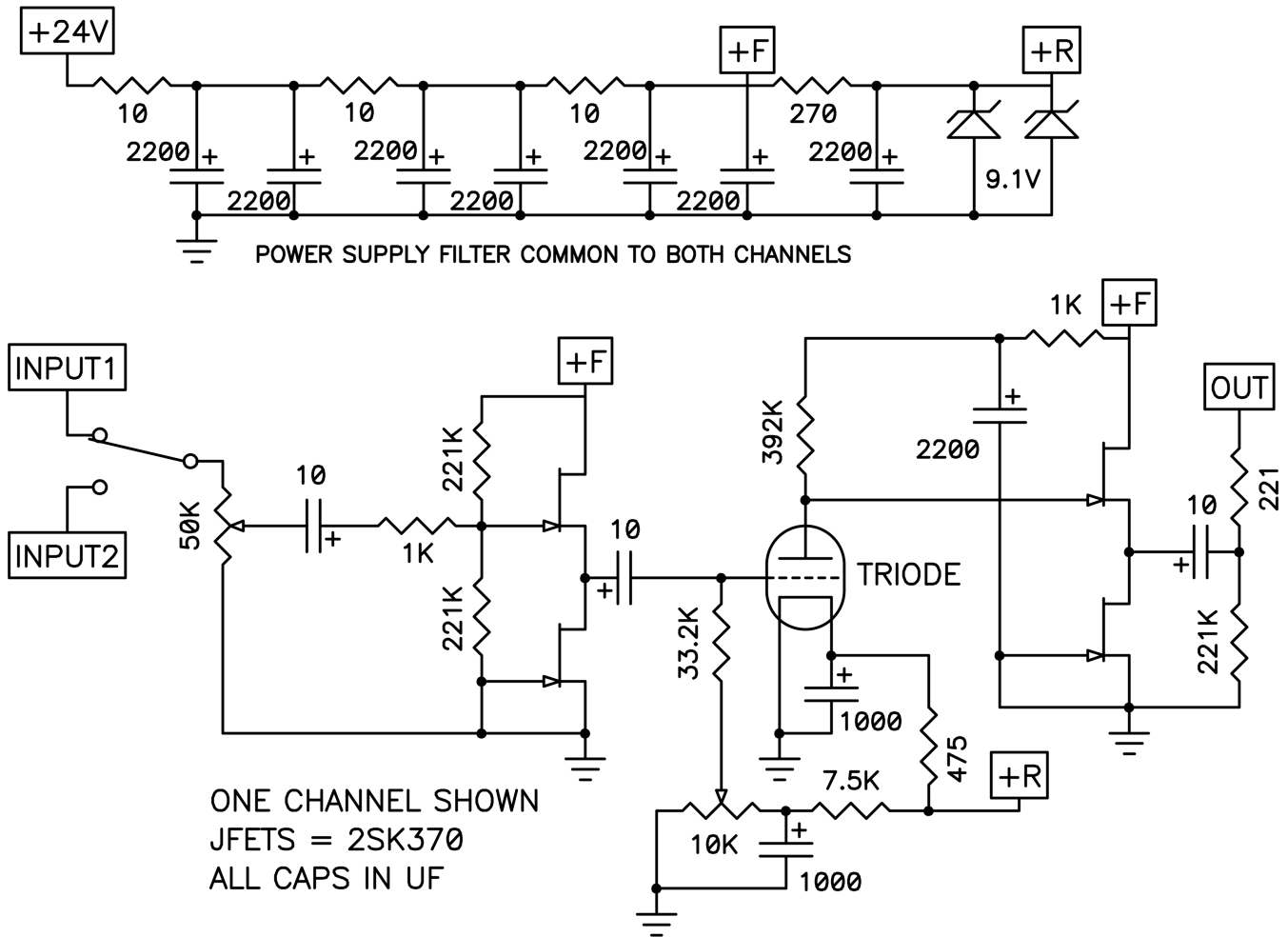

I experimented with numerous values, particularly the plate load resistor, looking for the optimal value for this circuit. I finally used 332 Kohm (please ignore the 392 Kohm on the schematic) which had more gain than the 10 dB I wanted but delivered the harmonic quality I was looking for at the higher output levels.

I also experimented with the bias settings, noting the quantity of 2nd harmonic distortion. Like other Triodes, it can be adjusted for positive or negative phase second harmonic, or at the point where 2nd harmonic has been nulled out.

After listening tests I settled on a value which gives a negative phase second harmonic at 1.5% with 1 volt output. This setting is dependent on the sensitivity of the loudspeakers and the gain of the power amplifier. In my case the loudspeakers are the Tannoy HPD 15" coaxials with a sensitivity of about 95 dB and an amplifier with voltage gain of 20 dB (Sony VFET amplifier from First Watt).

Here is what that distortion waveform looks like:

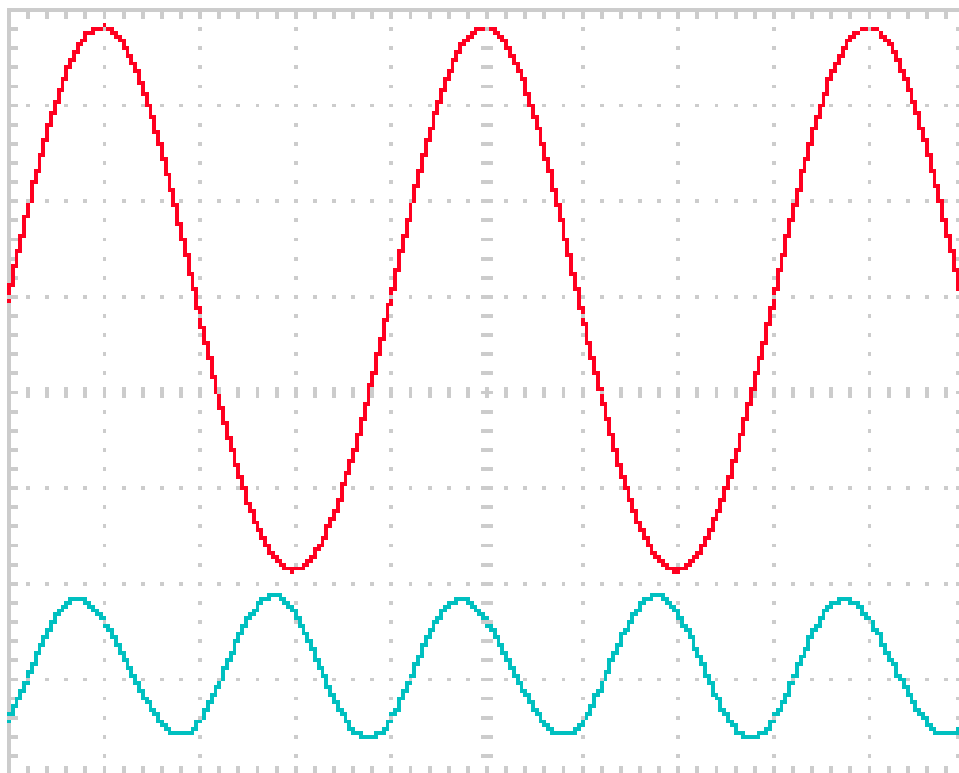

Note that because the circuit inverts the waveform, proper phase is retained by phase inversion in the chain that follows the preamp. Since the power amplifier does not invert phase, the connection to the loudspeaker was inverted.

Also, note that here the 2nd harmonic appears to be in phase with the fundamental, but when the output is inverted at the speakers, the phase of the distortion becomes negative as desired.

In the above waveform you see that the blue distortion 2nd harmonic is dominant, with the 3rd harmonic at about 20 dB lower than the second and a very low quantity of higher order harmonics.

Here is the distortion curve:

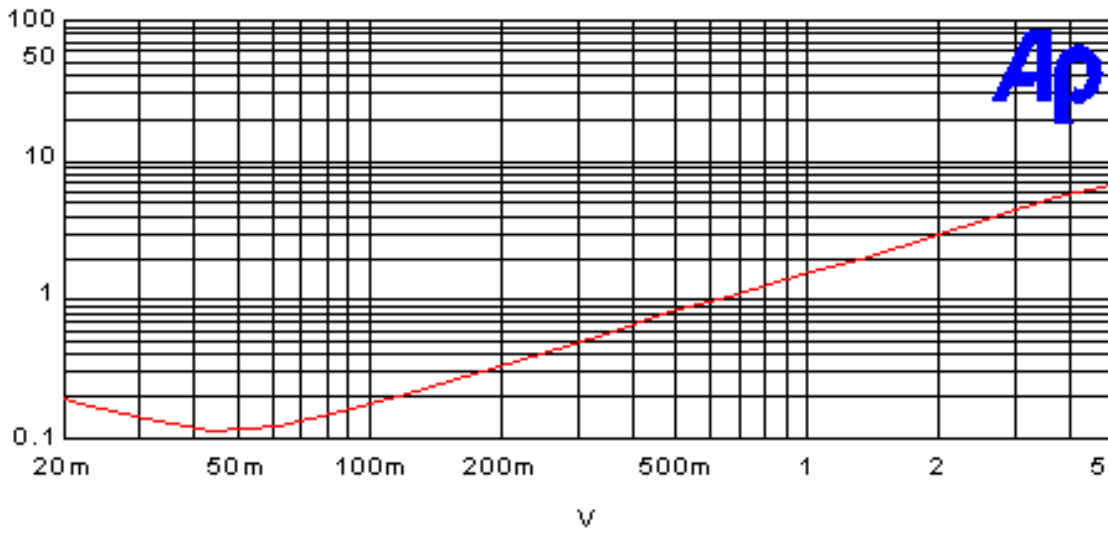

And here is the frequency response:

