

Technics SU-9070

Stereo DC Preamplifier



Professional Series

SU-9070 Stereo DC Preamplifier

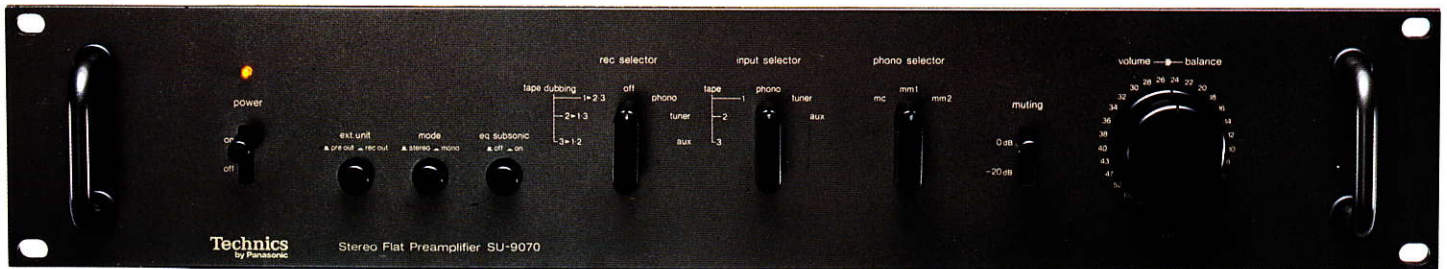

A Unique DC Preamplifier with Built-in Pre-Preamp for MC Cartridges—Aims at the Highest Possible Fidelity

To transfer the pure audio signal from the external source to the power amplifier—that is the goal of any preamplifier. Any trace of side effects like noise, distortion, coloration or phase shift can make you very aware that you're listening to electronic equipment rather than pure music. The SU-9070's design reduces these undesirable elements so drastically that they might as well not exist at all. So you'll hear nothing added or taken away—just excitingly clear, transparent sound.

Filling the Requirements vs. Challenging the Limits

If you think about it, a preamplifier doesn't have to do much to earn its name. It must transmit a signal without altering it significantly. In the case of phono reproduction, it must equalize the signal to conform to RIAA standards. It should provide some operational flexibility to permit taping, mode switching and volume control. The SU-9070 does these things and can thus be called a preamp. But a preamp with a difference. Because Technics' goal in designing the SU-9070 was more than fulfilling requirements. It was rather to challenge the limits of high fidelity preamp performance. We are confident that most listeners will be satisfied with our product. But it is the really demanding connoisseur—the professional or audiophile who has been exposed to very fine equipment—who will fully appreciate the subtle yet ultimately significant accomplishments reflected in the SU-9070.

Facts and Figures

Take a look at the facts; compare the figures. A phono S/N ratio of 88dB (2.5mV sensitivity). A DC flat amp for waveform fidelity. Plus, a selector redesigned to provide full versatility when using tape decks. Now see what we've left out. Various filters and, believe it or not, a tone control. In fact, the only frequency response altering device incorporated in the SU-9070 is a subsonic filter. The reason is simple, perhaps self-evident. It is just that a preamp that performs so much better than others would not try halfway to perform a function that is not legitimately its own. For the truth is that conventional tone controls and filters, even the more elaborate varieties, are imperfect tools when highly linear response in the total system is the objective.

If tone is to be controlled, it should be done thoroughly and properly; and the way to accomplish this is to use a stereo universal frequency equalizer, the SH-9010 being an outstanding example thereof. A look at the block diagram may give you a better idea of what we are talking about. Note the simple elegance of the MC pre-preamp, phono equalizer circuits, and DC flat amp. These circuits represent the solutions to the complex problems overcome by Technics in reaching the pinnacle of preamplifier design found in the SU-9070.

Extremely Quiet Phono Equalizer

For noise to be undetectable at high listening levels, it is essential that the phono equalizer have a high signal to noise ratio. In many preamps, equalizer noise becomes disturbingly noticeable when the volume is raised with the input selector in the phono position. Technics' SU-9070 does not have this problem because its unheard of S/N ratio of 88dB (2.5mV sensitivity) means that noise is reduced to an inaudible 1/25,000 fraction of the wanted signal.

A theoretical analysis shows that most noise consists of first stage amplification of heat noise caused by nothing other than input circuit resistance and first-stage transistor internal resistance. Therefore, if these can be lowered, a high S/N ratio can be achieved. But available so called low-noise transistors retain the problem of noise-causing internal resistance when used in the equalizer circuit. Reaching this seeming impasse, Technics

had no choice but to independently develop a new transistor to meet the specification required. The M47L is the amazing result. A pair of these ultra-low noise transistors is utilized in the differential amplifier first stage. And to further ensure extremely high signal to noise ratio, our unique current mirror loading technique is employed. For the realization of such a high S/N ratio, it was necessary to cut resistance in all elements of the equalizer circuit. One side-effect is the large current flow in the output section. To deal with this, a heat sink, rare in equalizers, has been added.

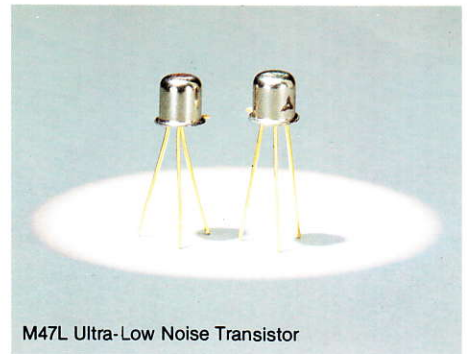

M47L Ultra-Low Noise Transistor

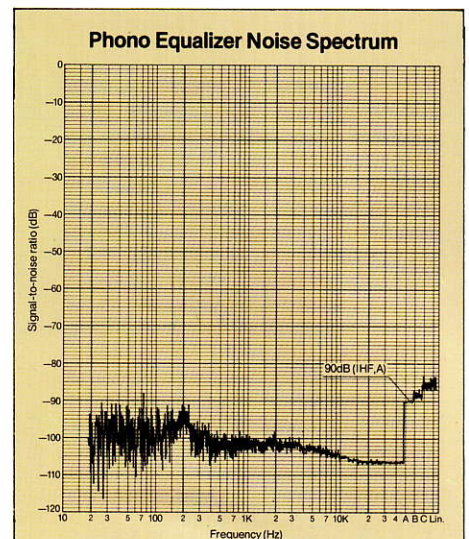
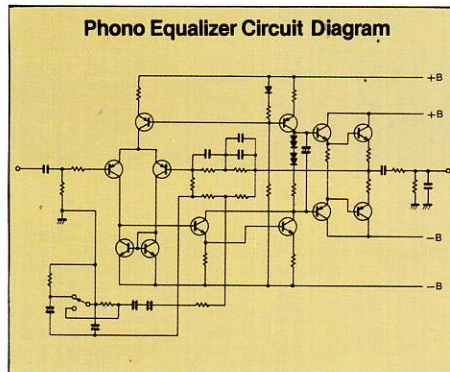

An Uncommon Pair: High Input Level Handling Ability Combined with Ultra Low Distortion

With a maximum undistorted permissible input of 380mV (at 1kHz), the phono equalizer amp can safely work with even the highest output signals that a modern phono cartridge can deliver when tracing discs of high cutting levels.

Distortion in this circuit is fought in two ways. First, the circuit has been designed for minimum distortion even without applying negative feedback; then, a generous amount of negative feedback is added to force down distortion to a level way below audibility—the accompanying graph shows *how* low. Please note that this very effective distortion reduction extends down into the low bass range where conventional NFB techniques often lose much of their efficacy. The SU-9070's equalizer is a four-stage direct coupled circuit consisting of current mirror load differential amp, constant current loaded voltage amp, and SEPP. $\pm 42V$ of high voltage is supplied for increased linearity in the first and voltage amp stages and to gain high maximum input capacity. The SEPP final stage delivers low distortion at low output impedance. Low output impedance is essential to avoid drops in output peak levels and rises in distortion when a tape deck with low-impedance input is connected to the rec out terminals. Metalized polyester film coupling capacitors are employed to reduce distortion even in areas beyond the audible frequency range.

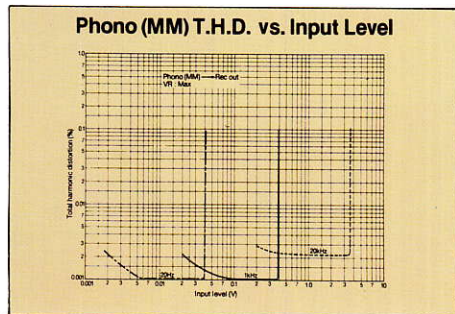

Accurate RIAA Characteristics ($\pm 0.2dB$)

RIAA frequency characteristics are determined by precision elements for a tolerance of only $\pm 0.2dB$ from the ideal curve. Components used include metal film resistors of 1% tolerance and polypropylene capacitors with a 2% tolerance specification. An indication of the caliber of engineering put to use here is the fact that, thanks to a high frequency compensation circuit, the equalization response keeps following the theoretically ideal curve even beyond the upper limit of the audible sound spectrum.

Built-in Subsonic Filter Stops Rumble

Low frequency noise caused by warped records or low frequency resonance determined by the tonearm's effective mass and

the cartridge's compliance may give rise to undesirable IM distortion in downstream stages, and may cause the woofer to vibrate uselessly. Subsonic filters incorporated in power or preamps prevent this noise from reaching the speakers. Technics has gone a step further by placing the subsonic filter in the negative feedback loop of the equalizer amp section. (Cut-off 20Hz, $-12dB/oct.$) Thereby IM distortion is stopped at the very source.

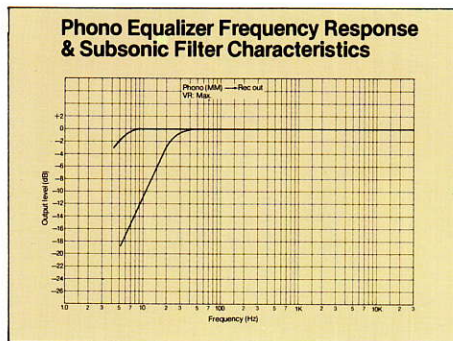

Ultra-Low Noise Pre-Preamp for MC Cartridges

Among audio connoisseurs the MM type cartridge has a large following. But there are some who prefer the unique characteristics and subtleness of the moving coil type. The problem is that the output signal of the MC type is so small that a special transformer or pre-preamp is required before the signal can be put into most preamps. MC cartridge fans will be glad to hear that the SU-9070 has an MC cartridge amp built-in so there is no need to purchase a separate piece of equipment. Available MC transformers have shown unfortunate frequency response characteristics and a tendency toward distortion. Technics has overcome all that with a circuit design breakthrough that ensures low distortion and an S/N ratio that approaches the ideal theoretical limits.

As mentioned above in the context of the phono equalizer, amp noise arises from circuit resistance noise. So, if there existed a perfect amplifier with zero circuit resistance, the S/N ratio would be decided only by the resistance caused when input is terminated. Assuming that this resistance amounts to 2.5 ohms, equivalent noise voltage at the input would therefore come to $-157dBV$. The SU-9070 pre-preamp's $-157dBV$ figure is astonishingly close to this ideal. Input sensitivity is rated at $60\mu V$; output is $2.5mV$. S/N ratio is 72dB, quite an achievement in a pre-preamp for MC cartridges. Another outstanding feature is that gain is stable irrespective of input load (cartridge output impedance). In sharp contrast to this, pre-preamps employing operation amp circuits, have reverse phase input and output while gain changes as a function of input load (a high impedance MC cartridge causes gain to fall). The difference between the S/N ratio of this type of pre-preamp and the type built-in to the SU-9070 can be clearly observed when a low impedance cartridge is used. On the other hand, since the input impedance of the

SU-9070's pre-preamp is sufficiently high, one may safely use a cartridge which requires a high matching load impedance.

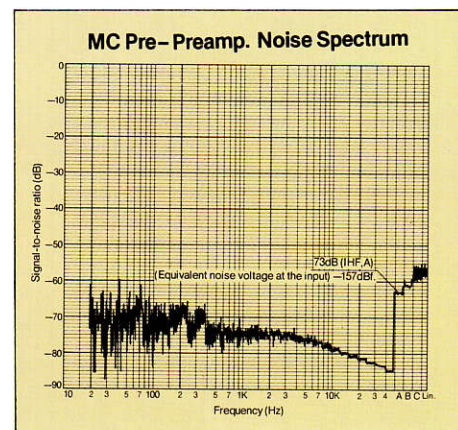
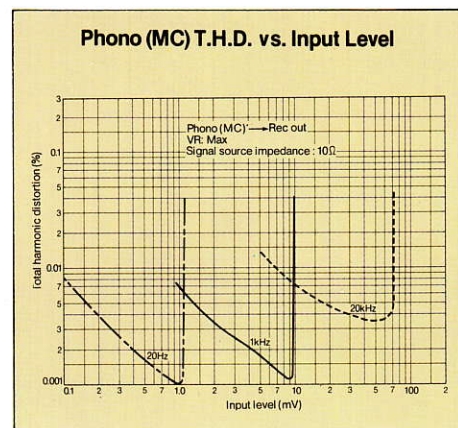

MC Pre-Preamp Circuit Features

Two M57L transistors, which surpass even the M47L of the equalizer circuit in performance, are used in parallel, grounded to the base in the first stage. The base ground enables input impedance reduction and, since the negative feedback is 100%, distortion control is another big advantage. Plus, the parallel connection means no noise. Including the voltage amplifier and output stage, all together, five transistors are used in the amplifier.

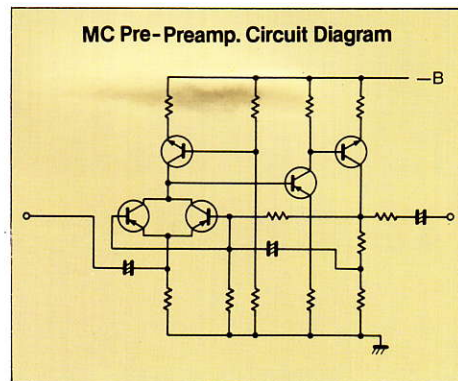

Total of 6 Gangs in Volume/Balance Controls

In this design, two resistors control balance and there are two for each channel's volume control. The volume control function is divided between the flat amp's input and output sides in such a way that the combined attenuation results in the minimum possible noise at any volume setting. At minimum position, output is grounded so that there is no noise at all when the volume is turned completely down. The volume control is marked in decibels and is a continuously adjustable type of the same high precision as an attenuator. Every effort has been made to ensure perfect tracking of channels with minimized left and right gang error.

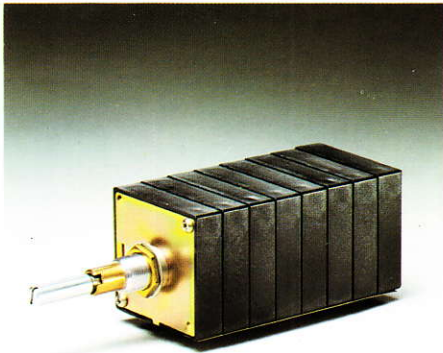

6-Ganged Volume/Balance Control

DC Flat Amp Assures Outstanding Waveform Fidelity

The flat amp is a DC amp without coupling capacitors at input or output. Capacitors have also been eliminated from the feedback loop. The DC amp holds gain to high levels and exhibits no phase shift in the low range, making for very good waveform fidelity.

DC Flat Amp Circuit Construction

The first stage consists of a matched, dual-FET, differential amp with current mirror load. The five-stage design is further made up of a pure resistance load voltage amp and an

SEPP output stage. The result is amazingly low distortion of below 0.003% at 1V output (VR: -30dB, 20Hz~20kHz). Through improving the thermal balance of the first stage, the DC amp's operational stability has been significantly enhanced.

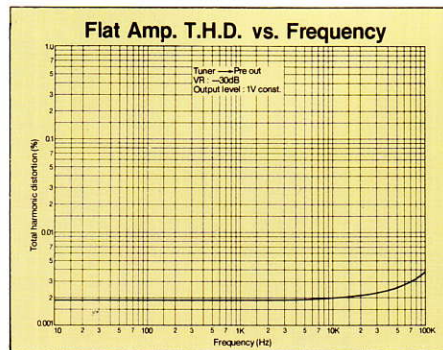
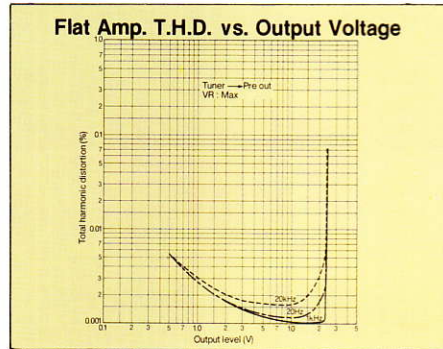
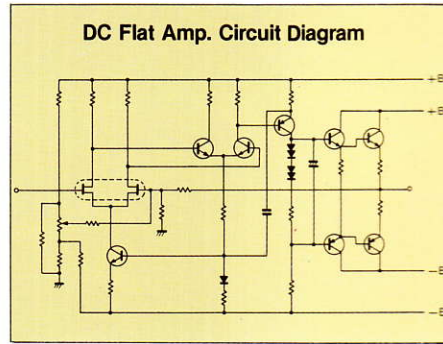

Double Muting Protection Includes Rec-Out

Since relay operated muting is provided for both pre-out and rec-out, there is no danger of shock noise reaching your power amplifier or tape deck when the amp is turned on.

Versatile Redesigned Input Selector Incorporates Tape Monitor

Until now, preamps had separate input selector and tape monitor switches. Why the tape monitor was left out is a moot point, but with the increasing attractiveness of tape decks, it's about time something was done to make preamp controls more logical.

Therefore, the tape deck is included as a signal source controlled by the input selector of the SU-9070. Three tape deck inputs are provided for in the selector switch along with phono, tuner, and auxiliary.

Another surprising feature is the entirely separate recording selector. This seven-way switch provides for any recording hook-up regardless of the position of the input selector. What this means is that you can record from any of three tape decks to either or both of the others or you can record from phono, tuner or auxiliary. With this capability it is no trouble to make a recording from your tuner while simultaneously listening to an album. Versatile capability is given by the three way phono selector that lets you decide between MC cartridge input and two inputs for MM or other high level cartridges.

External Unit Switch for Universal Frequency Equalizer

Both input and output sides of the UFE are to be connected to the preamp. With that done, one button on the front panel of the SU-9070 lets you decide where to insert frequency equalization in the signal path. Specifically, when the button is extended, the SH-9010 UFE processes the pre-out signal; when the button is depressed, it switches over to rec-out signal for controlled frequency response recording. This makes pre-emphasis recording and de-emphasis playback (with resultant noise reduction) more convenient and opens up new possibilities for creative recording.

Other Features:

- Stabilized voltage power supply is used to reduce crosstalk and single-channel transient distortion to an absolute minimum.
- Cut-core power transformer boasts low leakage flux, large capacity in a small package.



- 19" panel corresponds to EIA specifications for easy rack mounting.

Versatile Redesigned Input Selector

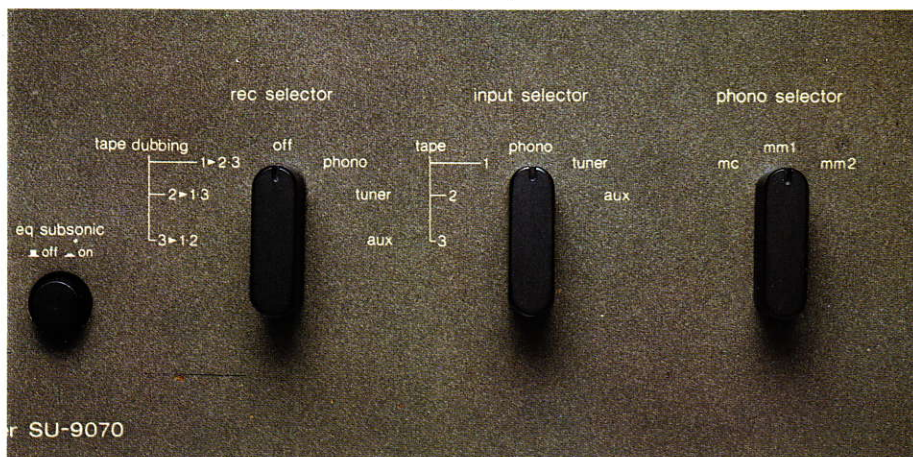

SU-9070

SU-9070 Block Diagram

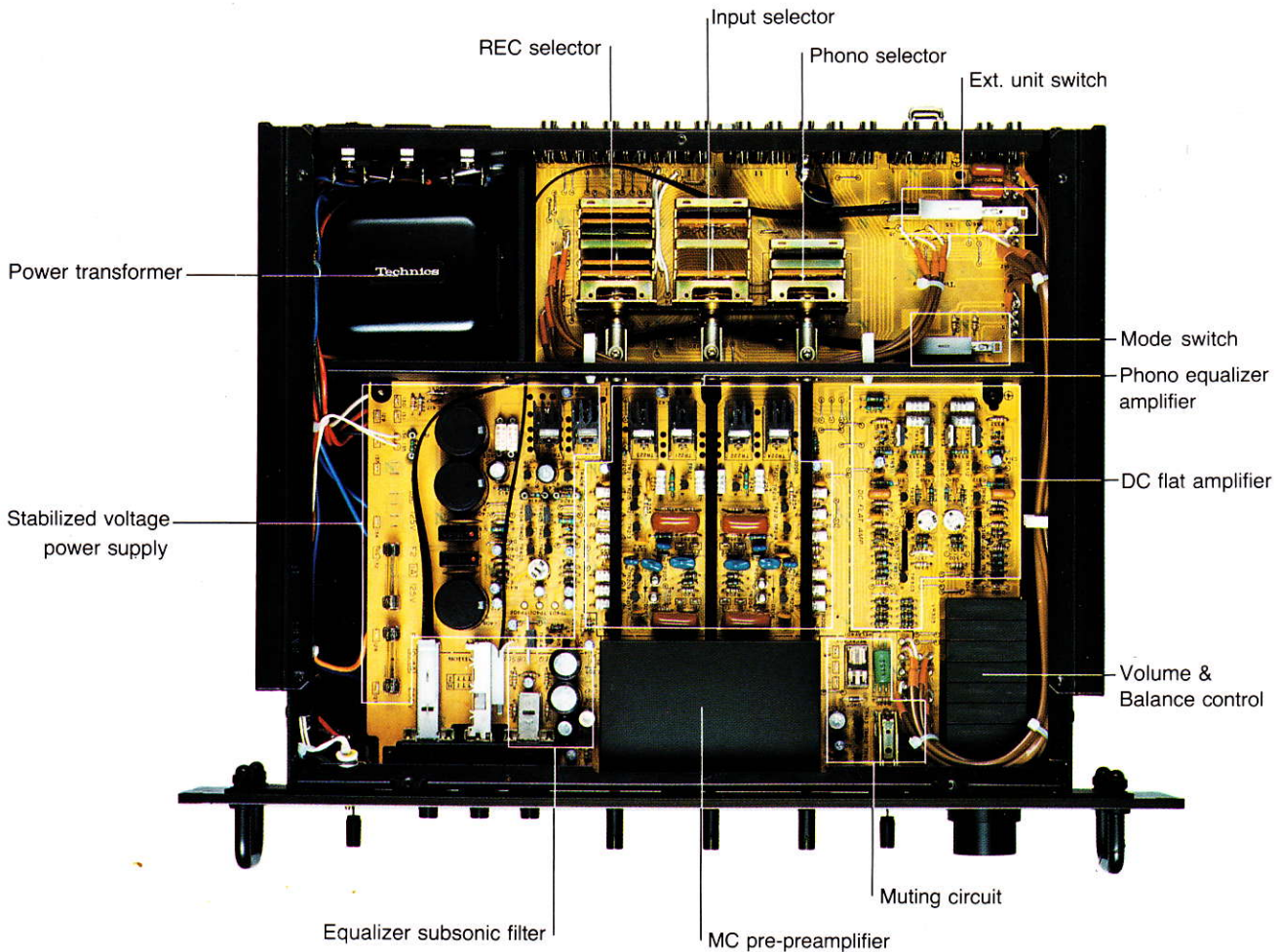
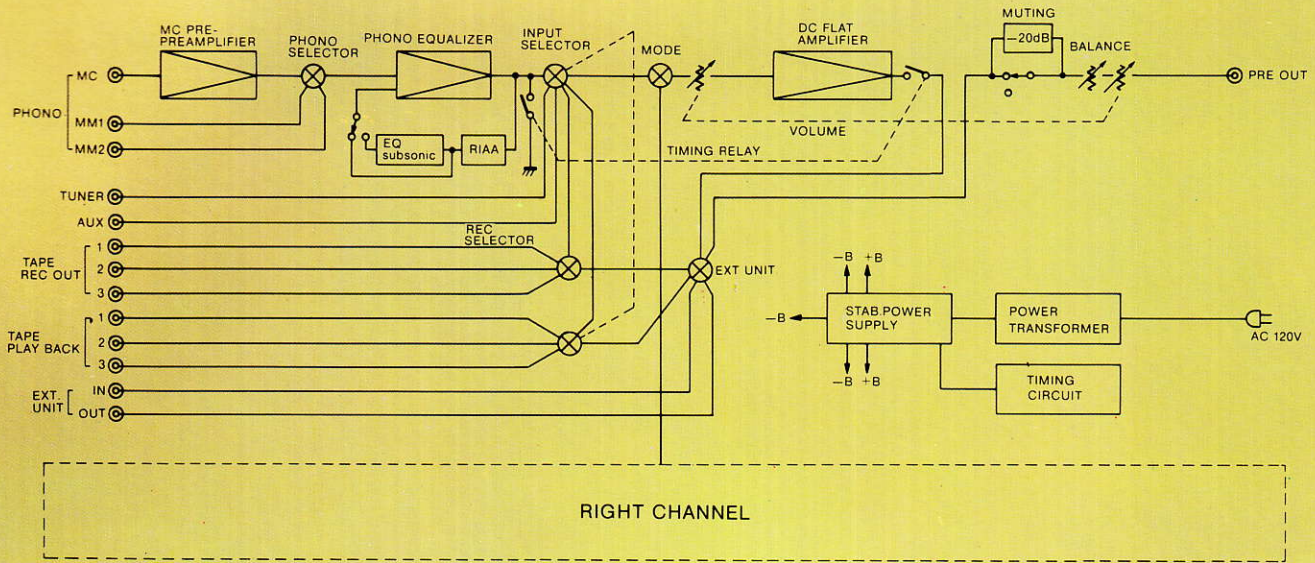

Rear Panel Facilities

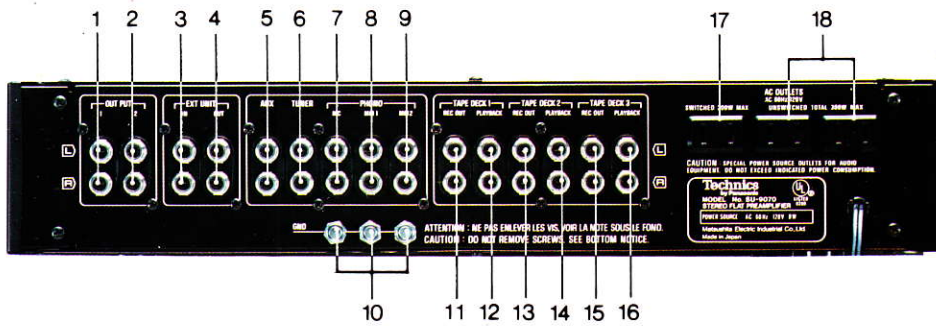

- | | | |
|--------------------------------|-----------------------------|-----------------------------|
| 1. Output terminals 1 (DC) | 7. Phono MC inputs | 13. Tape deck 2 REC outputs |
| 2. Output terminals 2 (normal) | 8. Phono MM 1 inputs | 14. Tape deck 2 PLAY inputs |
| 3. EXT unit inputs | 9. Phono MM 2 inputs | 15. Tape deck 3 REC outputs |
| 4. EXT unit outputs | 10. Ground terminals | 16. Tape deck 3 PLAY inputs |
| 5. AUX inputs | 11. Tape deck 1 REC outputs | 17. AC outlet (switched) |
| 6. Tuner inputs | 12. Tape deck 1 PLAY inputs | 18. AC outlets (unswitched) |

The "Flat" Component System is dedicated to ultimate performance at an affordable price.

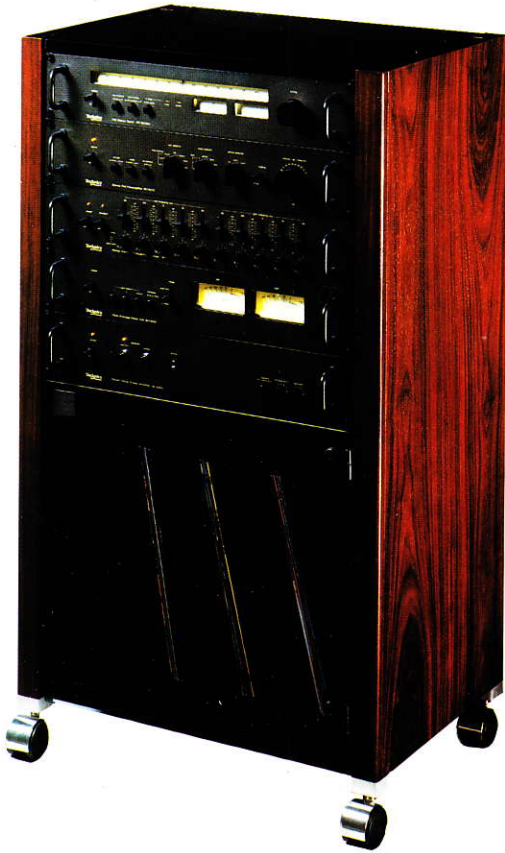

Ultimate performance. Because in creating the "flat" system Technics engineers separated the basic amplifier/tuner into five components. Researched and developed each component to state-of-the-art perfection. Then recombined the components into a system that provides a magnitude of performance once thought to be purely theoretical. Affordable price. Because each component is priced far lower than what you'd expect, considering its extraordinary quality. And because the five-way breakup lets you buy just the equipment that you need—or can afford—right now. With the possibility of adding the rest of the system in the future.

The "Flat" Component System consists of:
 ST-9030: FM Stereo Tuner
 SU-9070: Stereo DC Preamplifier
 SH-9010: Stereo Universal Frequency Equalizer
 SH-9020: Peak/Average Meter Unit
 SE-9060: Stereo/Mono DC Power Amplifier

Movable Custom Rack, Model SH-999

Elegant custom rack for Technics "Flat" components or other 19-inch units. Side panels rosewood grain veneer, glass top and front door. Record compartment holds several dozen LP's. Four sturdy casters for mobility and easy access to back panel connections.

Technical Specifications

Input sensitivity and impedance	
phono MM 1	2.5 mV/47 kilohms
phono MM 2	2.5 mV/47 kilohms
phono MC	60 μ V/47 ohms
tuner, aux	150 mV/47 kilohms
playback tape 1, 2, 3	150 mV/47 kilohms
Phono max. input voltage (1 kHz, RMS)	
phono MM	380 mV
phono MC	9 mV
Rated total harmonic distortion	
	0.003%
S/N ratio (IHF,A)	
phono MM	100dB (10mV input) 88dB (2.5mV input)
phono MC	72 dB
phono MC	
equivalent noise voltage at the input	
	-157 dBV
tuner, aux	106 dB
Total harmonic distortion (20Hz~20kHz)	
tuner, aux, tape	
VR, max	
at 10V output	0.003%
VR, -30dB	
at 1V output	0.003%
phono (MM)	
VR, max	
at 10V output	0.004%
VR, -30dB	
at 1V output	0.004%
phono (MC)	
VR, max	
at 10V output	0.02%
VR, -30dB	
at 1V output	0.01%
Frequency response	
phono	20Hz~20kHz RIAA \pm 0.2dB
tuner, aux	20Hz~20kHz +0dB, -0.05dB DC~100kHz +0dB, -1dB
Equalizer subsonic filter	
	20Hz, -12dB/oct.
Muting	
	-20dB
Output voltage and impedance	
pre out rated	1V/600 Ω
max.	20V/600 Ω
rec out tape 1, 2, 3	150mV

GENERAL

Power consumption	30W
Power supply	AC 120V 60Hz
Dimensions	
(H x W x D)	3-31/32" x 19" x 14-17/32"
	(101 x 482 x 369mm)
Weight	15.7 lb (7.1 kg)

Technics

Panasonic Company

Division of Matsushita Electric Corporation of America

EXECUTIVE OFFICES: One Panasonic Way, Secaucus, New Jersey 07094 (201) 348-7000
 PANASONIC NEW YORK: 50 Meadowlands Parkway, Secaucus, New Jersey 07094 (201) 348-7000
 PANASONIC NEW JERSEY: 50 Meadowlands Parkway, Secaucus, New Jersey 07094 (201) 348-7000
 PANASONIC BOSTON: 75 University Avenue (P.O. Box 487, Norwood, Mass.), Westwood, Massachusetts 02090 (617) 326-4000
 PANASONIC BALTIMORE: 11 Azar Court, Baltimore, Md. 21227 (301) 247-4300
 PANASONIC CHICAGO: 425 East Algonquin Road, Arlington Heights, Ill. 60005 (312) 364-7900
 PANASONIC ATLANTA: 1 Mecca Way, Duluth, Georgia 30136 (404) 448-1100
 PANASONIC DALLAS: 1825 Walnut Hill Lane, Irving, Texas 75062 (214) 258-2828
 PANASONIC WEST, INC.: 8383 Wilshire Blvd., Beverly Hills, Calif. 90211 (213) 655-1111
 PANASONIC SALES COMPANY: Ave. 65 de Infrantera, Km. 9.7, Victoria Industrial Park, Carolina, Puerto Rico 00630 (809) 769-4320
 PANASONIC HAWAII, INC.: 320 Waiakamilo Road, Honolulu, Hawaii 96817 (808) 847-5361

Technics SH-9010

by Panasonic Stereo Universal Frequency Equalizer

AUDIO / HI-FI



Professional Series

SH-9010 Stereo Universal Frequency Equalizer



The SH-9010 Permits Delicate Frequency Response Control Totally Unattainable with Conventional Tone Controls or Graphic Equalizer

Any professional's or serious audiophile's system includes some means of adjusting the frequency response of the programs to be played or recorded. The tone controls on a preamplifier or integrated amplifier, and the graphic equalizer which has been available for some years as a separate unit, are designed to provide such control of frequency response. But both of these methods have serious limitations:

Tone Control Limitations

Tone controls are designed to act upon the sounds at the two ends of the audio frequency spectrum. However, it is normally not at the very ends but on the center side of the ends that some sort of sound compensation is required. When normal tone controls are utilized to make such adjustments, the result is an unavoidable increase or decrease in the level at some other place where such adjustment is not necessarily desired. The result is a loss of the naturalness of the music. This is exactly why many audiophiles prefer to listen to their music with the tone controls in the defeat position.

A variety of methods have been devised to overcome this difficulty. Variable turnover frequencies have been provided and sometimes an additional tone control for the midrange has been added. However, all of these methods are clearly insufficient.

Graphic Equalizer Limitations

The graphic equalizer is used for controlling frequency response in professional recording studios and theaters, and compared with tone

controls is considerably more versatile. The graphic equalizer divides the frequency spectrum into several bands and controls frequency response by boosting or attenuating each band as necessary. However, the performance of the graphic equalizer—as well as its price—depends upon the number of bands the frequency spectrum is split into, and the best professional units which allow control at intervals of $\frac{1}{3}$ octave are quite expensive. Naturally, as the number of bands is reduced, performance also is adversely affected.

The Stereo Universal Frequency Equalizer Opens Up Completely New Control Capabilities

Conventional equalizers, as useful as they are in audio work, all suffer from two critical drawbacks which severely limit their scope of applications.

First, each slide pot boosts or attenuates a fixed, immovable frequency band. We speak of "fixed center frequencies." No matter how these frequencies are chosen and spaced, however, it is only in rare cases that they will be at precisely the spot where boost or attenuation is desired.

Technics Offers Variable Center Frequencies

In a radical departure from the circuit principles found in conventional equalizers, Technics has designed the SH-9010 with variable frequencies; by turning the control

knob below each slide pot, the center frequency can be moved up or down by as much as 1.6 octaves. The five slide pots provided for each channel thus cover the following ranges:

Normal Center Frequency	Variable Between
60Hz	20Hz—180Hz
240Hz	80Hz—720Hz
1kHz	333Hz—3kHz
4kHz	1.3kHz—12kHz
16kHz	5.3kHz—48kHz

As this adjustment is continuous, center frequencies can be set at accurately the desired points. What's more, settings are independent for each stereo channel. This flexibility gives the user unlimited freedom in coping with every imaginable equalization problem.

Between every two adjacent frequency ranges, there is an area of overlap a little over an octave in width. By moving both center frequencies to the same spot, available boost or attenuation can be further enlarged. Frequency response graphs shown elsewhere on these pages indicate some of the fascinating possibilities afforded by this unique Technics feature.

Unlike conventional equalizers, the Technics SH-9010 has no "blind spots" between adjoining bands. Yet this is only one of its two outstanding flexibility features that make it such a pliant tool in the hands of the experienced audio technician and demanding audiophile. The other:

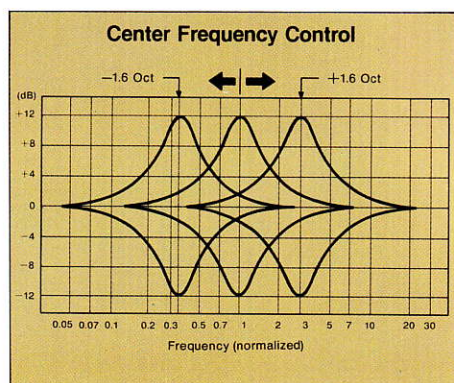
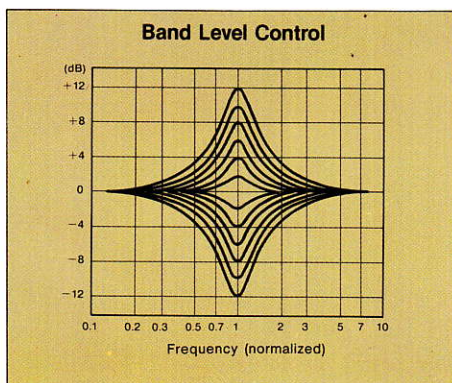
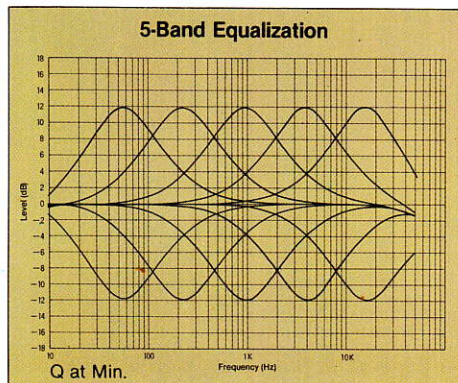

Variable Bandwidth ("Q") of Each Band

As shown in the illustration below, "Q" is an expression of the steepness with which attenuation or boost slopes near the center frequency. The higher the value of Q, the steeper the slope (and the narrower the bandwidth covered).

In conventional equalizers, Q has fixed value, slope steepness is constant and unalterable. Equalization jobs in actual audio work, however, are often greatly hampered by this inflexibility. A slight boost (or attenuation) over a relatively wide spectrum, for instance to improve sonic balance in an orchestral recording, calls for a gradual slope (a low Q) in order to remain unobtrusive. Noise or hum reduction jobs, on the other hand, are often concerned with only a very narrow band in which noise is present and require a very steep attenuation slope over a narrowly defined band (high Q). In many cases, a fixed equalizer bandwidth forces an unacceptable compromise upon the audio technician.

Not so in the Technics SH-9010. Here, the Q for each band is continuously adjustable from 0.7 (a very gradual slope covering a relatively wide band) to 7 (a very steep gradient limited to a quite narrow band). Some sample graphs are shown elsewhere on next page, illustrating the range of adjustment possibilities available.

As with the variable center frequencies, "Q" adjustment is also independent for each band of each stereo channel.

The SH-9010 thus offers an infinite number of combinations of three types of adjustment:

1. Boost or attenuation by up to 12dB at five points in the frequency spectrum, in both stereo channels.
2. Precise setting of any or all of these five bands to any frequency, with more than an octave of overlap between two adjacent bands.
3. Free adjustment of "Q" (or bandwidth) for each frequency band, within the range of $Q = 0.7$ to 7.

Equalizer In/Out Switch for Instant Comparisons

In position "out" of this switch, the entire equalizer network is bypassed and the source signal heard without any modification. This permits instant comparisons between "raw" and "equalized" sound. An indicator lamp lights up in "equalizer in" position.

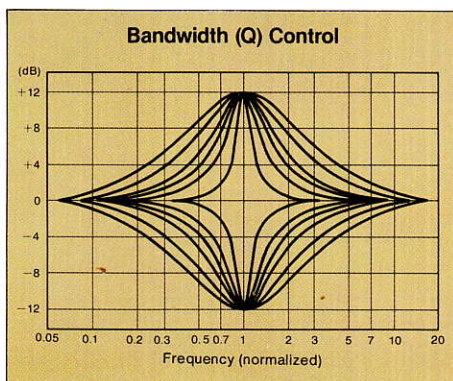

Detent Stops in Neutral Position

At its "0" position, where no boost or attenuation takes place, each slide pot has a detent. The neutral position can be easily found without as much as reading the scales.

Two Pairs of Outputs

On the rear panel, one pair of input jacks and two pairs of outputs are provided, permitting equalized output to be supplied to a power amplifier and a tape deck, for example. An auxiliary AC outlet is also provided, for powering another system component.

Some Typical Applications of The Universal Frequency Equalizer

Instead of Amplifier Tone Controls

A number of preamplifiers of very high quality are now on the market in which tone controls have been purposely omitted—SU-9070 is one example. The Technics Universal Frequency Equalizer, installed downstream from the preamp, will give immensely greater control flexibility than any system of amplifier tone controls.

Flattening of Overall System Response

While components of a system, when measured individually, may exhibit nearly ideal response curves, the total system including speakers and installed in a listening room often suffers obvious dips and peaks. The equalizer can restore flat overall response with a high degree of precision.

Suppression of Standing Waves

Parallel walls of a listening room cause standing waves to form, usually in the bass-to-medium range, which can be extremely annoying because of the boominess that they impart to the sound. An attenuation setting of the equalizer, usually in combination with a narrow bandwidth setting, can usually remove this boomy quality.

Compensation for Frequency Non-Linearities of Phono Cartridges

Moving magnet (MM) type cartridges often exhibit two kinds of non-linear frequency response: mid-range slumping, and high end peaking. The former occurs over a fairly wide range of frequencies, while the latter is rather narrow and sharp. With normal methods, it is extremely difficult to correct this difficulty, but the SH-9010 handles this task with ease.

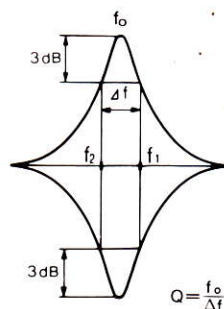

Definition of "Q"

Where f_0 is the resonance frequency and Δf is the bandwidth between the -3 dB level points (f_1, f_2).

Typical MM Cartridge Frequency Response

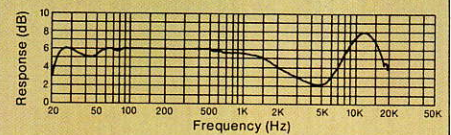

Equalizer Response for Compensation. Result: Flat Response



Restoration of Sonic Balance in Re-Recording Older Program Material

Old SP's and early LP's often sound unsatisfactory because recording equalization standards employed in their production differed from those used today (or were determined merely by the recording engineer's whim). The Universal Frequency Equalizer can restore a great deal of sonic balance and make them very listenable. With rare collector's items, it is common practice to re-record them on tape with improved equalization.

Denosing of Program Material

Annoying hum, hiss, scratchiness, tonearm resonances, high end distortions and other "garbage" fortunately occupies portions of the frequency spectrum which are not of critical importance to the musical information. The Universal Frequency Equalizer can be a miraculous tool in cleaning up such programs, especially with its freely variable frequency band and attenuation slope settings.

Improved Signal-to-Noise Ratio in Tape Recordings

By boosting the high end when recording, and applying an equivalent amount of attenuation in playback, annoying tape hiss can be forced down below audibility level. (The high end boost must not exceed the tape's "headroom", however, as this would trade noise against distortion.)

Bandwidth Limitation and Sonic Balancing in Live Recording

In live recording, the frequency range occupied by the music is usually known in advance, being determined by the instruments used. In such cases, it is often advisable to suppress the musically irrelevant frequency extremes, thereby avoiding noise that may otherwise try to creep into those unoccupied bands.

The equalizer can also be quite helpful in improving the instrumental or vocal balance in live ensemble recording, as microphone settings must often compromise on account of hardware or room limitations.



Slide Pot
 Bandwidth (Q) Control
 Center Frequency Control

Variations in Level, Center Frequency, and Q permit an Astoundingly Wide Range of Audio Processing

By properly adjusting the SH-9010, delicate changes in frequency response can be achieved. A few examples:

- By adjusting level and Q together, a wide variety of peaks and dips can be created. Graph 1 shows Q at maximum and the level control at various positions. Graph 2 shows Q at minimum, with the level control at various positions.
- Greater degree of boost and attenuation is obtainable by "stacking" center frequencies. The inner line in Graph 3 shows the center frequency of just one band. The outer line shows what happens when the center frequencies of two bands are made to coincide. Q is at maximum for both. Graph 4 shows the same effect, but with Q at minimum.
- Complex frequency response curves can be achieved by combining peaks and dips. In Graph 5, the broad black curve shows the peaks when Q is at minimum, while the other black curve shows the dips when Q is at maximum. The red and black lines shows the composite of the two. In Graph 6, the broad black curve shows the peaks when Q is at minimum, while the other black curve shows the peaks with Q at maximum. The red and blue lines show the composite.

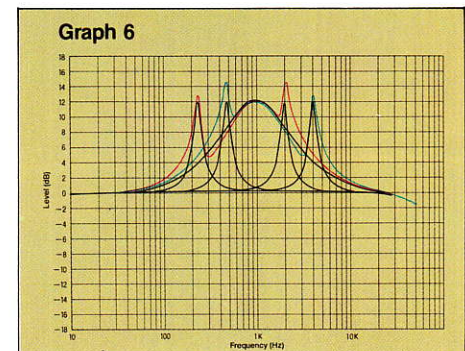
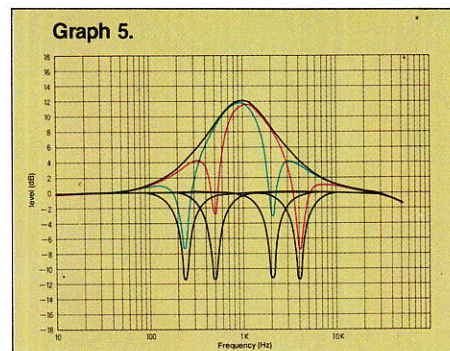
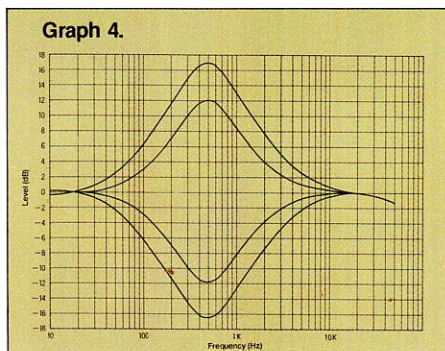
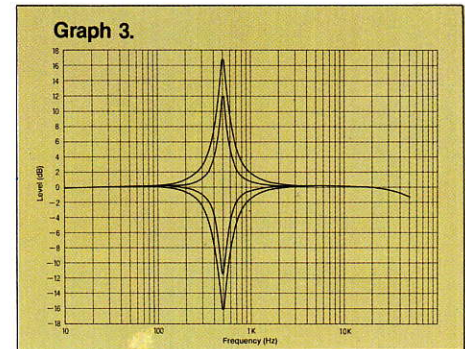
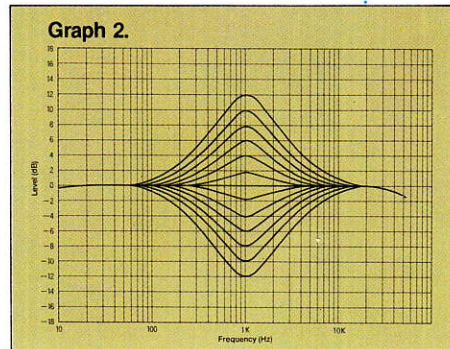
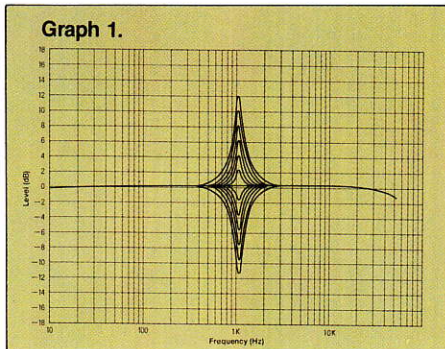

The Technology behind Variable Center Frequencies and Bandwidth

Conventional bandpass filters employ induction coils, and these do not permit variations in bandwidth or frequency. Moreover, they display some undesirable characteristics in regard to noise and distortion parameters. For these reasons, the SH-9010 is equipped with a newly developed type of active filter called "dual integration filter," using operation amp ICs. The hardware for each filter consists of one adder-subtractor and two integrators. Its function is best explained as the sum of a high-pass filter, a bandpass filter (B.P.F.), and a low-pass filter, operating in series. By varying the resistances in each feedback loop, center frequency f_0 and bandwidth "Q" can be altered independently, and a change in one does not cause a variation in the other.

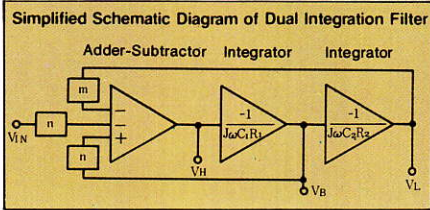

No conventional filter circuit can achieve this flexibility. Similarly elaborate circuit construction has been adopted for the attenuation/boost of each band. The complex filter circuitry described above is here shown in simplified form as the "B.P.F." block. In addition, there are two amplification stages. Assuming that the slide pot is in $+K$ position, the B.P.F. block operates in parallel with the input resistance of the 2nd amp. As composite impedance drops, this results in higher gain and thus a boost of that particular band. Conversely, with the slide pot in $-K$ position, negative feedback occurs in the 1st amplification stage, reducing gain and thus causing a dip in this band. The circuit is laid out in such a way that precisely symmetrical

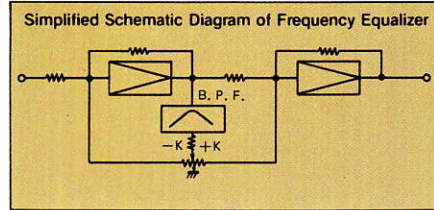

attenuation and boost are obtained with slide pot settings symmetrical relative to center. With the slide pot in center position, the bandpass filter's output is grounded, meaning that the filter has no effect whatsoever and that the incoming signal is passed on as it is. To decouple the equalizer circuitry from influences of equipment connected upstream and downstream, a high impedance buffer amplifier and an output amplifier of low output impedance have been included.

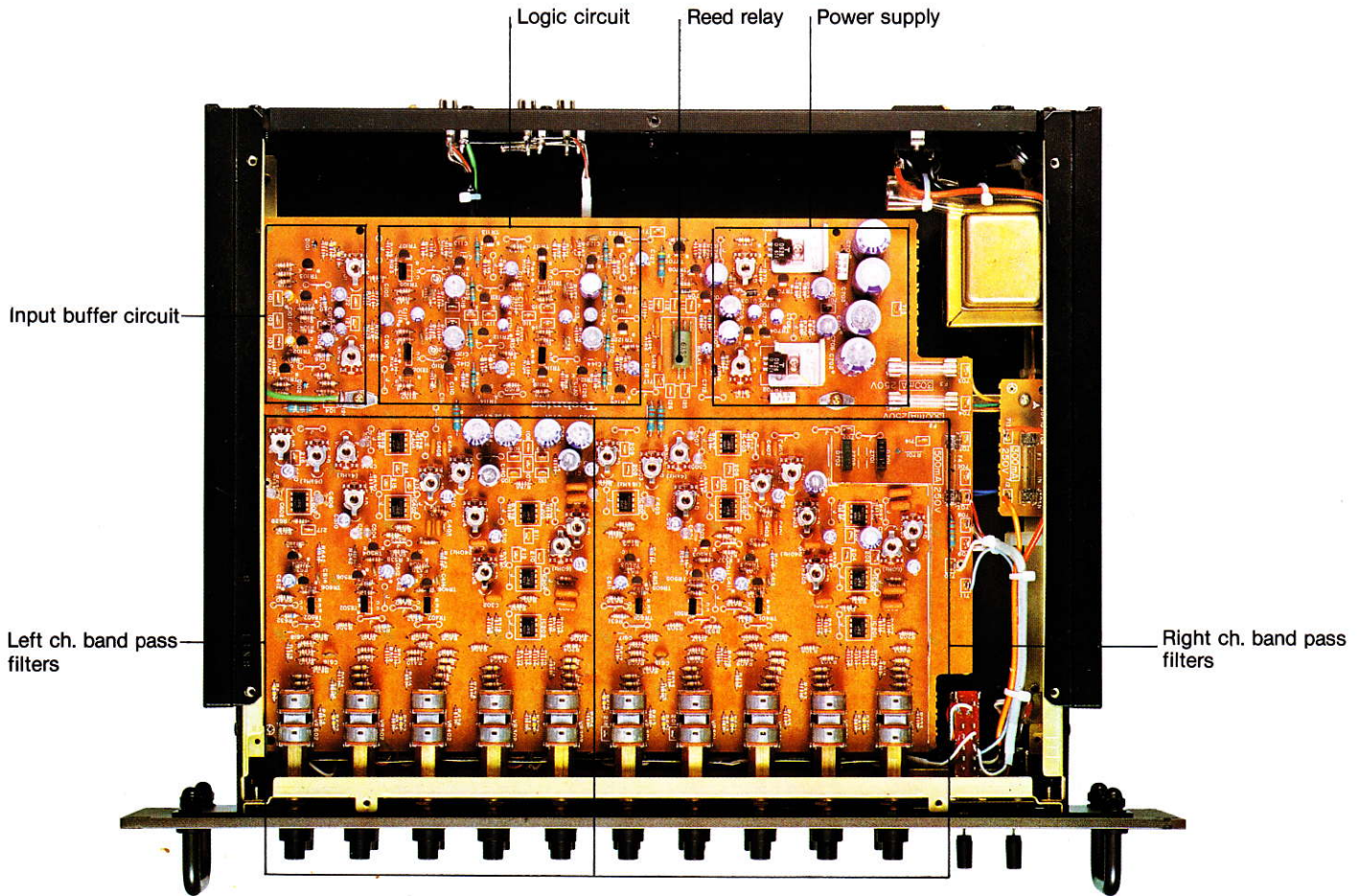
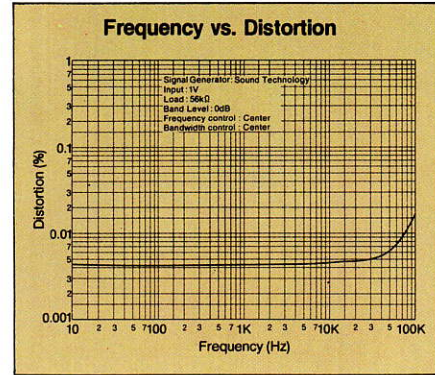

Rear Panel Facilities

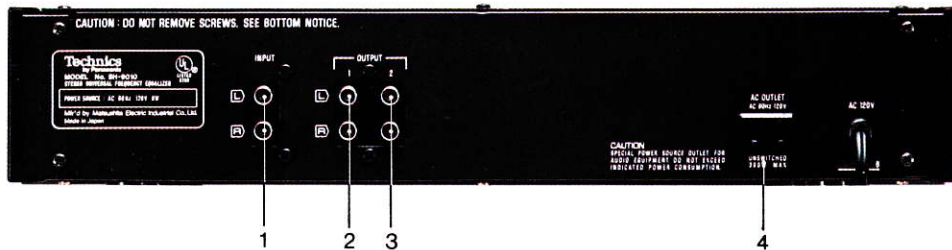

1. Input terminals
2. Output terminals 1
3. Output terminals 2
4. AC outlet

The "Flat" Component System is dedicated to ultimate performance at an affordable price.

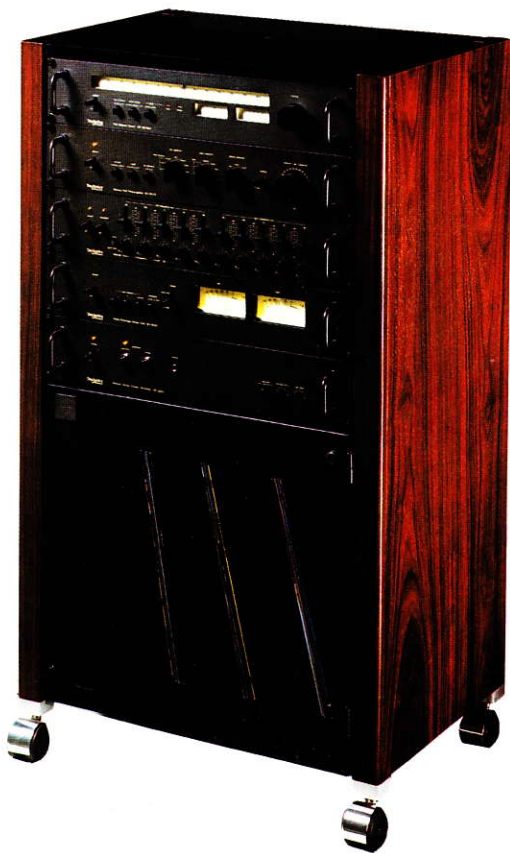

Ultimate performance. Because in creating the "flat" system Technics engineers separated the basic amplifier/tuner into five components. Researched and developed each component to state-of-the-art perfection. Then recombined the components into a system that provides a magnitude of performance once thought to be purely theoretical. Affordable price. Because each component is priced far lower than what you'd expect, considering its extraordinary quality. And because the five-way breakup lets you buy just the equipment that you need—or can afford—right now. With the possibility of adding the rest of the system in the future.

The "Flat" Component System consists of:
 ST-9030: FM Stereo Tuner
 SU-9070: Stereo DC Preamp
 SH-9010: Stereo Universal Frequency Equalizer
 SH-9020: Peak/Average Meter Unit
 SE-9060: Stereo/Mono DC Power Amplifier

Movable Custom Rack, Model SH-999

Elegant custom rack for Technics "Flat" components or other 19-inch units. Side panels rosewood grain veneer, glass top and front door. Record compartment holds several dozen LP's. Four sturdy casters for mobility and easy access to back panel connections.

Technical Specifications

Output voltage/impedance	
rated	1 V/300 ohms (1 kHz)
max.	5 V/300 ohms (1 kHz)
Total harmonic distortion	0.02%
Input sensitivity/impedance	1 V/47 kilohms (1 kHz)
Frequency response	10 Hz ~ 20 kHz +0, -0.2 dB 10 Hz ~ 70 kHz +0, -3 dB 0 ± 1 dB
Gain	
Signal-to-noise ratio (IHF:A)	90 dB
Band level control	+12 dB ~ -12 dB (5 elements × 2)
Center frequency control	+1.6 oct. ~ -1.6 oct. (5 elements × 2)
Bandwidth (Q) control	0.7-7.0 (5 elements × 2)
Center frequency	60 Hz, 240 Hz, 1 kHz, 4 kHz, 16 kHz

GENERAL

Power consumption	8 W
Power supply	AC 120 V 60 Hz
Dimensions (H × W × D)	3-31/32" × 19" × 14-11/32"
	(101 × 482 × 364 mm)
Weight	13.2 lb (6.0 kg)

Harmonic Distortion

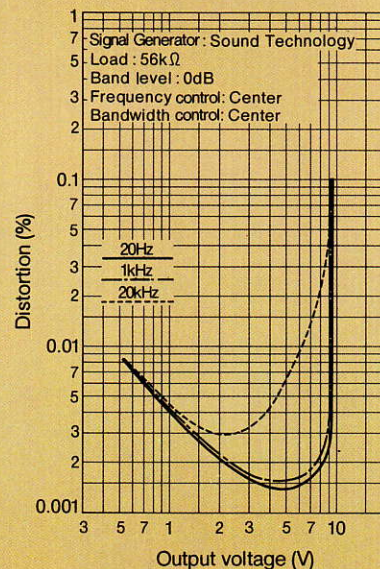

Technics

by Panasonic

Panasonic Company

Division of Matsushita Electric Corporation of America

EXECUTIVE OFFICES: One Panasonic Way, Secaucus, New Jersey 07094 (201) 348-7000

PANASONIC NEW YORK: 50 Meadowlands Parkway, Secaucus, New Jersey 07094 (201) 348-7000

PANASONIC NEW JERSEY: 50 Meadowlands Parkway, Secaucus, New Jersey 07094 (201) 348-7000

PANASONIC BOSTON: C.C. & F. Industrial Park, 31 Suffolk Road, Mansfield, Mass. 02048 (617) 339-9115

PANASONIC BALTIMORE: 11 Azar Court, Baltimore, Md. 21227 (301) 247-4300

PANASONIC CHICAGO: 363 N. Third Avenue, Des Plaines, Ill. 60016 (312) 299-7171

PANASONIC ATLANTA: 1 Meca Way, Duluth, Georgia 30136 (404) 448-1100

PANASONIC DALLAS: 1825 Walnut Hill Lane, Irving, Texas 75062 (214) 258-2828

NEWCRAFT, INC.: 8383 Wilshire Blvd., Beverly Hills, Calif. 90211 (213) 655-5160

PANASONIC SALES COMPANY: Ave. 65 de Infanteria, Km. 9.7, Victoria Industrial Park, Carolina, Puerto Rico 00630 (809) 769-4320

MATSUSHITA ELECTRIC OF HAWAII, INC.: 320 Waiakamilo Road, Honolulu, Hawaii 96817 (808) 847-5361

Specifications subject to change without notice. Printed in Japan 67765M3

Technics ST-9030

FM Stereo Tuner

AUDIO/HI-FI



Professional Series

ST-9030 FM Stereo Tuner

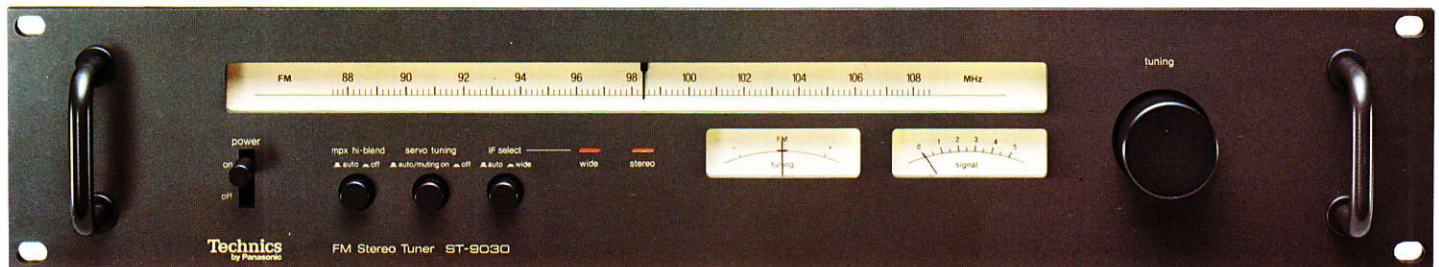

Waveform Fidelity — a True Measure of Tuner Performance

Staggering as the ST-9030 technical specifications may seem, the real test of true high quality performance lies in waveform fidelity. Although the waveforms of all signals in music programs are usually extremely complex, there are two relatively simple forms—the square wave, and the tone burst signals that will clearly show how well the tuner performs.

The comparison here between Technics ST-9030 (where design considerations were all aimed at waveform fidelity) and a conventional tuner (where waveform fidelity has not been of prime importance) clearly illustrates the logical conclusion resulting from a

critical difference in approach to this means of testing quality and performance.

The very steep "sag" in the square wave output signal in the conventional tuner indicates poor amplification phase characteristics in the low frequency region (thus introducing distortion), while the suppressed sections at the start of the 1kHz sine wave signals signify a contracted dynamic range in the low frequency region. The ST-9030 shows clear superiority over the conventional tuner. Although the time lag is not so critical if it is consistent, the unstable response patterns, the shortened leading edge amplitudes and the ringing during the off times will introduce audible distortion.

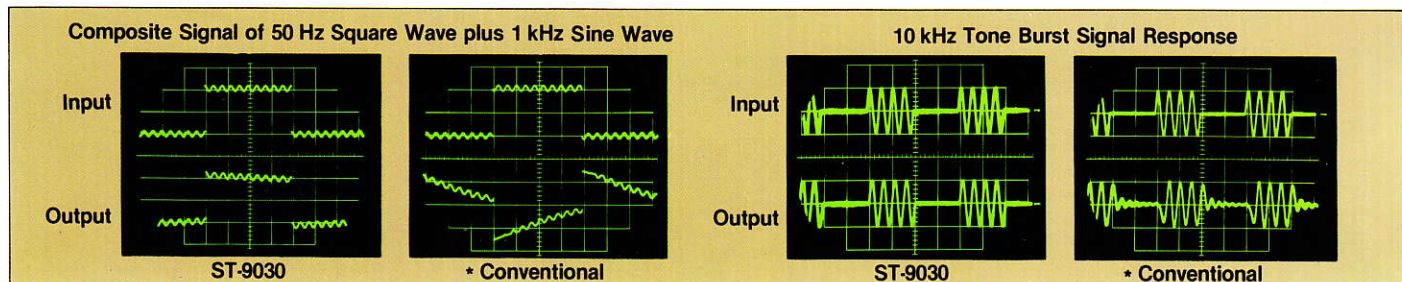

* Representative performance of high-quality tuners which use a conventional low-pass filter. The difference in performance between these and the ST-9030 is largely attributable to Technics' use of the more advanced pilot signal canceller.

The Ultimate in FM Performance, Featuring Fully Automatic IF Band Selection for Optimum Reception Condition

Frequency Response 20Hz—18kHz (+0.1dB, -0.5dB) Alternate channel selectivity 90dB (narrow band)
Sensitivity 1.2 μ V (75 Ω) and T.H.D 0.08% (stereo, wide band)

Superb FM Tuner for Superb FM Reception

The ST-9030 tuner, designed exclusively for high quality FM reception, achieves an incredibly high level of performance which would have been considered almost impossible only a few years ago. This welcome situation has been brought about by a profusion of very significant electronic and technological advances. For example, the 19kHz FM pilot signal is removed in the ST-9030 by a very imaginative pilot cancel circuit, instead of the less efficient low-pass filter. An extremely linear frequency response extending right up past 18kHz is the exciting result. Another example is revealed in the IF

stage, which has been divided into independent "narrow" and "wide" bands, selected automatically in the ST-9030 according to transmission conditions. Even in very congested regions, the astronomical alternate channel selectivity of 90dB completely eliminates even the slightest trace of interference from adjacent stations, while in less crowded areas the wide band elevates reception quality to a super grade, with sensitivity of 1.2 μ V, and a distortionless THD of only 0.08% for both stereo and mono. Other outstanding features include servo tuning, automatic hi-blend, a PLL MPX IC, and an FM linear frequency 8-ganged variable tuning capacitor in the front-end. When it comes to high quality reception of FM programs, the ST-9030 is the right kind of FM tuner where only the best will do.

Two Completely Independent NARROW and WIDE Band IF Stages with Automatic Selection of Optimum Conditions

One of the more exciting advances featured in the ST-9030 is the independent, dual, narrow/wide band IF stage. For many years, tuner designers had been searching for ways

of getting around the problem posed by the effects of mutually antagonistic high selectivity and low distortion. It was very difficult to improve one without resulting in

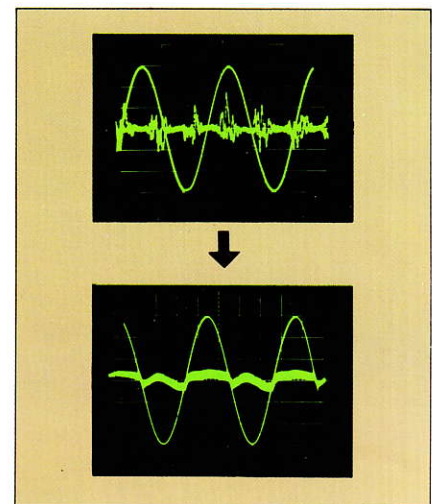

Effect of Automatic Bandwidth Switching

When distortion exceeds 0.3% due to adjacent station interference or other causes (top signal trace), bandwidth is automatically switched to narrow to restore low-distortion reception (bottom trace).

the deterioration of the other. Technics has solved this problem by incorporating 2 completely independent circuits in the IF stage—a narrow band for ultra sharp selection of wanted signals, and wide band for optimum S/N ratio and negligible distortion. The ST-9030 selects the appropriate band automatically in accordance to reception conditions, but manual selection is also available.

Wide Band IF

Since this band will normally be used in situations where selectivity is not of such critical importance, distortion, stereo separation, and capture ratio have all been pushed to the very limits of measuring capabilities. Employing compact 6-pole LC filter of outstanding group delay characteristics, plus 6-stage differential amplification, total harmonic distortion (stereo and mono) is reduced to an almost unprecedented 0.08%. Superb stereo separation ratings of 50dB (1kHz) and 40dB (10kHz), and a capture ratio as low as 0.8dB have also been achieved.

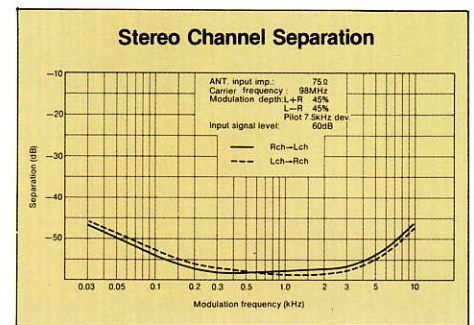
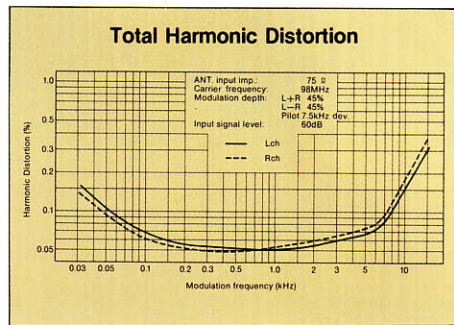

switches over to the wide band. But if the input signal is too weak, or if adjacent station signals are too close to the desired signal, causing spurious and/or crossmodulation interference, the tuner will remain switched to the narrow band.

Although detection of input signal level is quite a simple task, detection of adjacent station interference requires a very complex circuitry. The ST-9030 is designed to switch over to the narrow band if interference noise causes the S/N ratio (during stereo) to drop below 50dB (0.3% distortion).

signal remover which avoids cutting out any of the high end portions of the program, is an original Technics invention, first introduced in the Technics ST-9700 several years ago. Besides contributing to greater waveform fidelity, it is also very instrumental in reducing distortion in the very high frequency regions of the program.

By comparing the demodulation spectral distributions of 10kHz modulated signals in the ST-9030 and a conventional tuner, the vast improvement achieved by the cancel circuits becomes very clear indeed. The ST-9030 shows much less generation of higher harmonics and other unwanted components caused by beat phenomena.

A 19kHz signal supplied by the IC, and which has been synchronized perfectly with the pilot signal, undergoes waveform shaping into a pure 19kHz signal, and is amplified in the stereo muting circuit (which passes the 19kHz signal only during stereo). This is then fed back to the input side of the MPX to cancel out the unwanted pilot signal, thus avoiding any problems in subsequent non-linear circuits.

PLL MPX IC with Pilot and Subcarrier Cancel Circuits

The recent development of an IC for the PLL type MPX stereo decoder circuit has resulted in far reaching improvements, such as lower distortion level, higher stereo separation, and capacity to cope with the "shock noise" occurring in conventional systems. But one of the major features of this circuit is the pilot cancel circuit. Although now appearing in many other tuners, this imaginative

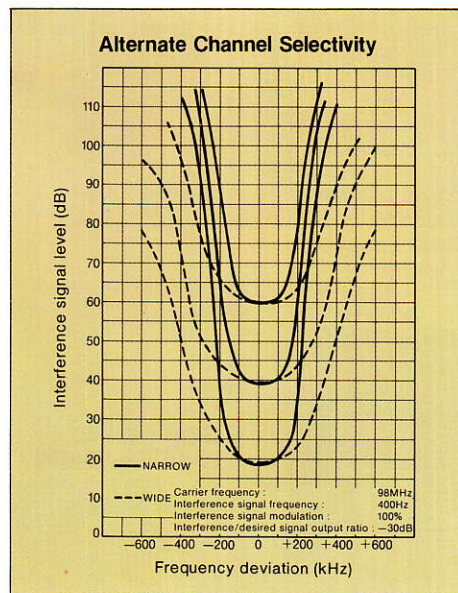

Narrow Band IF

By employing 4 separate 4-resonator ceramic filters (a total of 16 resonators) which exhibit very good group delay characteristics, a buffer amplifier, and 6-stage differential amplification, the ST-9030 attains the exceptionally high alternate channel selectivity of 90dB (400kHz) while still maintaining very good stereo separation (40dB at 1kHz, and 30dB at 10kHz), and very low distortion levels (mono 0.15%, stereo 0.3%).

Signals from the mixer circuit pass through both IF circuits, and feed into the detector circuit where selection of the appropriate IF band occurs. When the IF Selector is set to the "Auto" position, the tuner will initially switch over to the narrow band. If the input signal level exceeds 32.6dBf, or if the frequency difference (Δf) between the tuned station and the closest adjacent station is greater than 400kHz, the tuner automatically

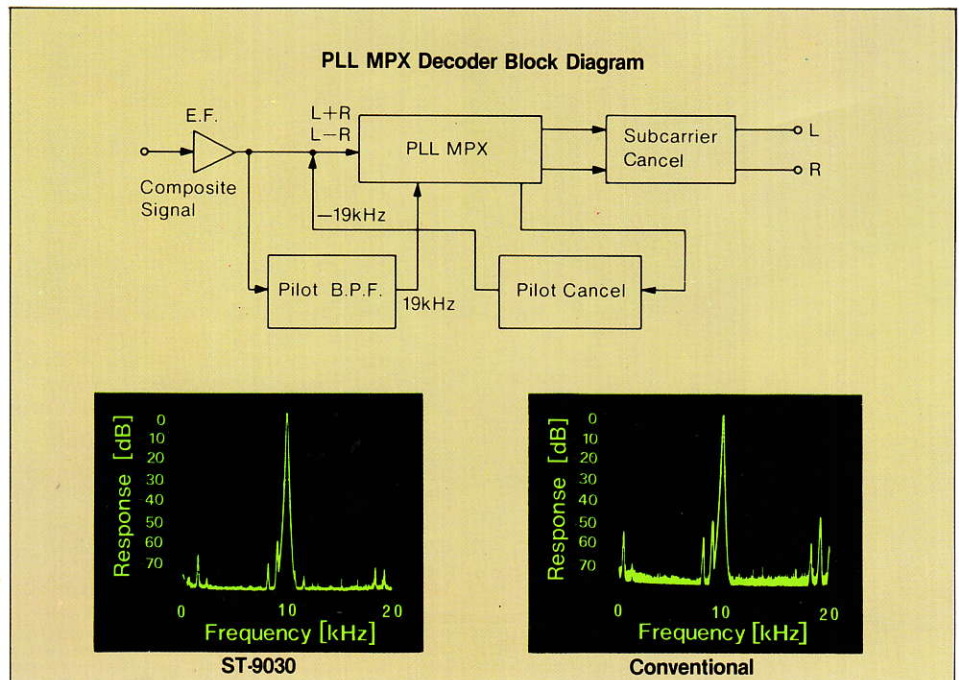

Effect of Pilot Cancel Circuit

Output spectrum when f. mod. 10kHz input is applied. Left: ST-9030—note almost complete absence

of 19kHz and other unwanted components. Right: Conventional tuner without pilot cancel circuit.

Extended Frequency Response of 20Hz~18kHz (+0.1-0.5dB)

Because the stereo decoding pilot signal is now eliminated by the electronic pilot cancel circuit, rather than a low-pass filter (which unavoidably removes some of the wanted program as well), frequency response in the ST-9030 is improved by a very significant margin. In addition, a cancel circuit for removal of the 38kHz sub-carrier has also been included. The resultant flat frequency response all the way from 20Hz to 18kHz with only +0.1, -0.5dB deviation gives an exceptionally high degree of high fidelity that is still very rare in tuners today.

The ST-9030 has also eliminated the cause of the "jitter" problem caused by mixing modulated input signals in the MPX. Deterioration of stereo separation, and distortion in the high frequency region is thus suppressed even further.

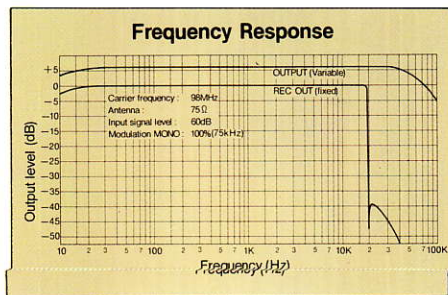

Servo Tuning Circuit for Stable and Accurate Tuning

Practically invincible stability in station tuning is assured by this advanced electronic device which locks onto the tuned frequency, and stays there despite any minor fluctuations in carrier frequency, local oscillator frequency, or IF center frequency. This means greater reliability due to the complete absence of drift which could lead to distortion and loss of stereo separation.

When retuning to another station, servo tuning is temporarily switched off. The muting width (the degree of detuning before muting sets in) is also readjusted, contracting from $\pm 100\text{kHz}$ when servo tuning is on, to $\pm 50\text{kHz}$ when switched off. Furthermore, the center tuning meter is locked to within $\pm 10\text{kHz}$ of the center position when servo tuning is on.

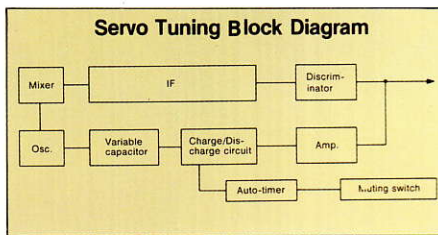
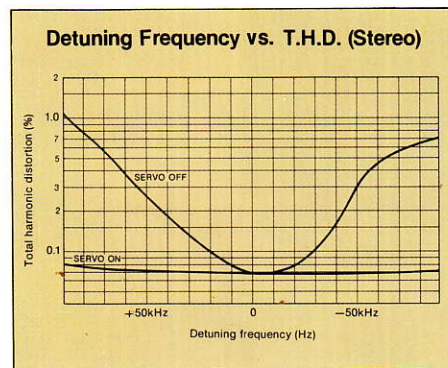

High Sensitivity Front-End Equipped with FM Linear Frequency 8-Ganged Variable Tuning Capacitor

The ST-9030 tuner's front-end, one of the most critical stages in any tuner, is equipped with an advanced linear frequency 8-ganged variable tuning capacitor. The improvement in sensitivity and reduction of noise levels is also due in part to the adoption of 3 double-tuned circuits, plus dual gate MOS FETs in the 2-stage RF amplifier and the balanced mixer circuit. The use of special low-noise transistors in the local oscillator, and a tuned buffer circuit inserted prior to the mixer, also contribute to the very high stability in this tuner. The tuned buffer circuit employed here is a combination of tuning circuit and junction FET, including a 2-ganged variable capacitor. It is very effective in maintaining waveform fidelity and preventing any reverse effect of RF signals.

These innovations have made the ST-9030 extremely robust, being capable of handling even exceptionally strong signals without overload. Spurious response and other basic characteristics have also been improved by very significant degrees. Furthermore, "hot" portions of the circuitry have been elevated above the glass epoxy coated circuit board, eliminating yet another potential degradation of the ST-9030's waveform fidelity.

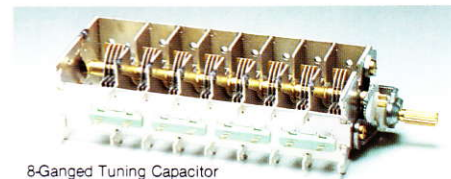
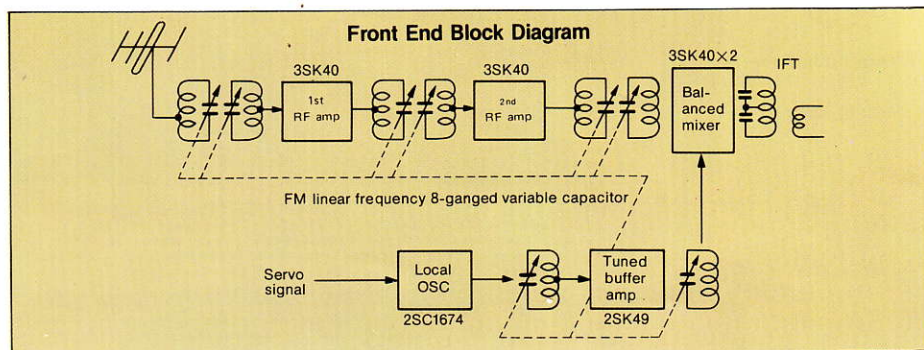
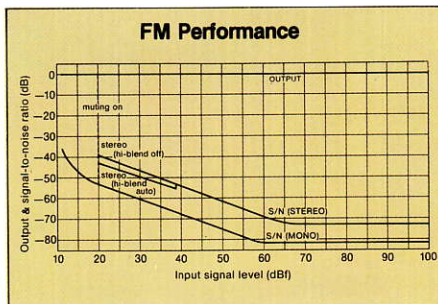

Automatic Hi-Blend Switch Improves Weak-Area S/N

To further improve the quality of rather distant or weak FM stations, the hi-blend feature in the ST-9030 is operated automatically (although switch-over to manual operation is also naturally provided). When the input stereo signal drops below a level of 34.7dBf, the hi-blend mechanism is activated automatically to suppress noise at the slight expense of some stereo separation.

Positive Muting in Narrow and Wide Band Operation Made Possible by NAND Muting

Complete muting of inter-station noise has now been made possible by the NAND muting switching system which automatically sets the muting width and level in accordance with signal level and whether narrow ($\pm 50\text{kHz}$) or wide ($\pm 120\text{kHz}$) bandwidth is being used at any given moment. This has been made possible by the independent regulation of muting level and muting width by the signal level and DC signal.

Other Important Features

- Precision signal meter linear to as high as 81dBf, thus providing accuracy in measuring even very strong signals.

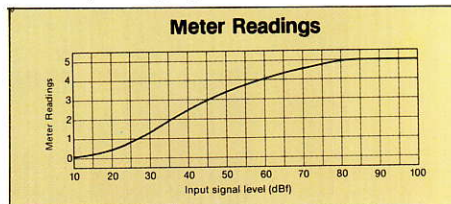

- Special 75 ohm F-type antenna connector for co-axial cable. 75 ohm cable is strongly recommended in the interest of noise-free reception.
- AC power supply line-filter to eliminate ripples and other interference signals induced via the AC power cord.
- High performance monolithic operation amplifier IC for audio frequency amplification, and independent constant voltage supplies for both radio and audio frequency amplification circuits.

ST-9030 Block Diagram

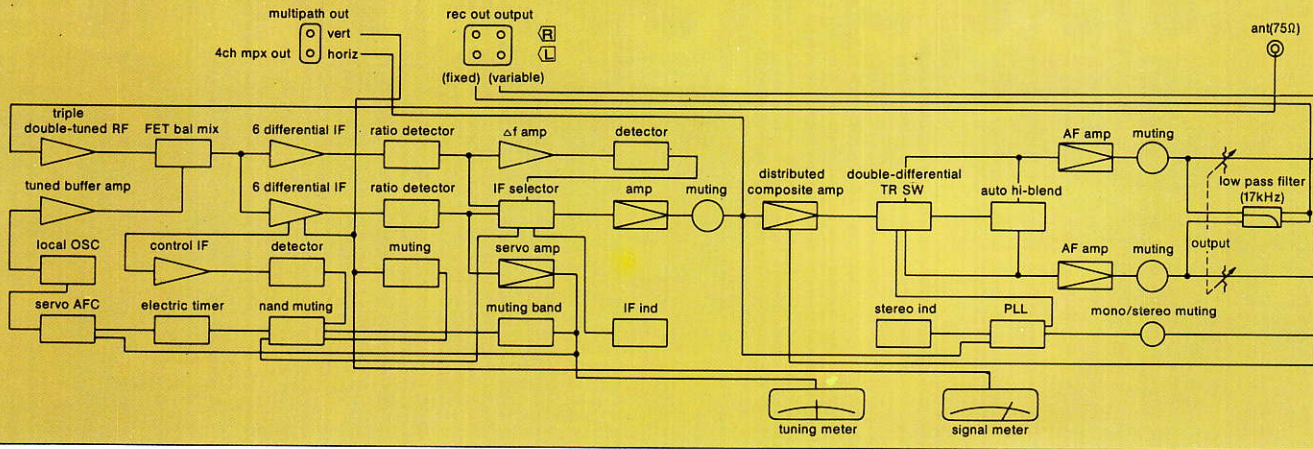

IF Stage Block Diagram

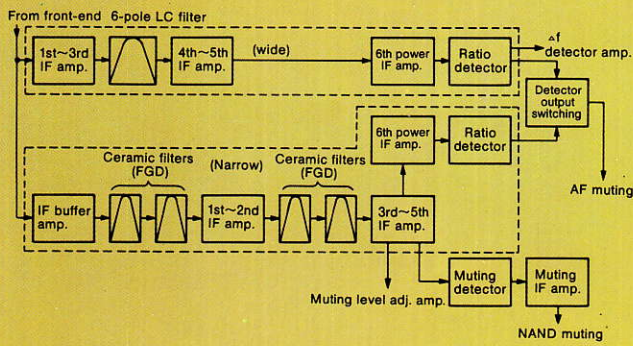

Block Diagram of IF Control Functions

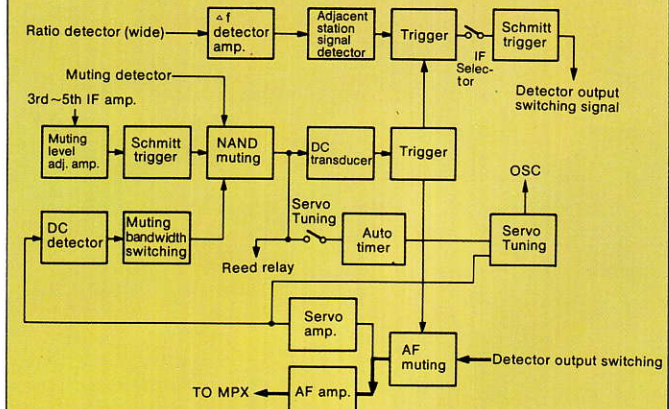

Flat group delay block filter

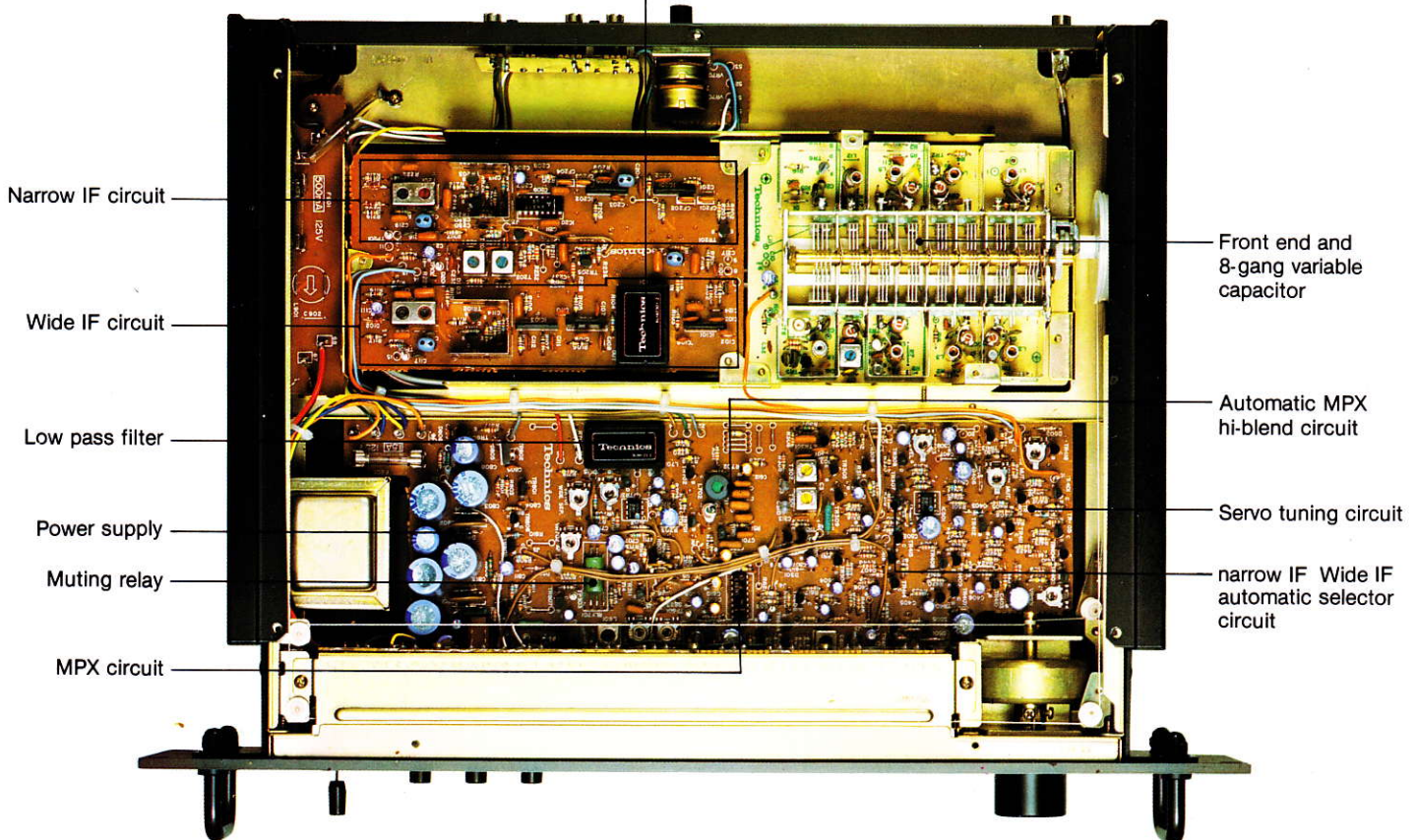

Rear Panel Facilities

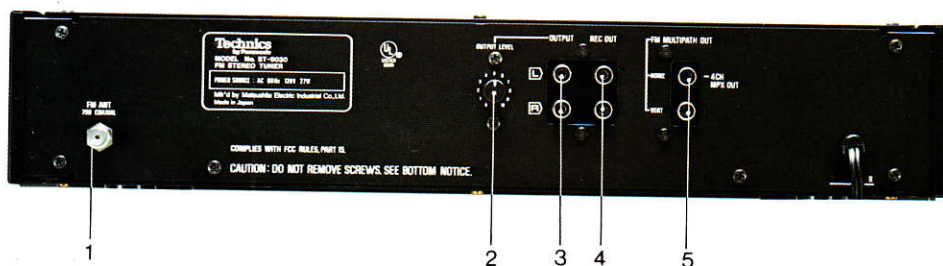

1. Terminal for FM antenna 75Ω coaxial cable
2. Output level control
3. Output terminals (Variable)
4. Output terminals (Fixed)
5. 4-channel MPX output & FM multipath outputs

The "Flat" Component System is dedicated to ultimate performance at an affordable price.

Ultimate performance. Because in creating the "flat" system Technics engineers separated the basic amplifier/tuner into five components. Researched and developed each component to state-of-the-art perfection. Then recombined the components into a system that provides a magnitude of performance once thought to be purely theoretical. Affordable price. Because each component is priced far lower than what you'd expect, considering its extraordinary quality. And because the five-way breakup lets you buy just the equipment that you need—or can afford—right now. With the possibility of adding the rest of the system in the future.

The "Flat" Component System consists of:
 ST-9030: FM Stereo Tuner
 SU-9070: Stereo DC Preamplifier
 SH-9010: Stereo Universal Frequency Equalizer
 SH-9020: Peak/Average Meter Unit
 SE-9060: Stereo/Mono DC Power Amplifier

Movable Custom Rack, Model SH-999

Elegant custom rack for Technics "Flat" components or other 19-inch units. Side panels rosewood grain veneer, glass top and front door. Record compartment holds several dozen LP's. Four sturdy casters for mobility and easy access to back panel connections.

Technical Specifications

Frequency range 88 ~ 108 MHz
 Antenna terminal 75 ohms (unbalanced)
 Sensitivity 12.8 dBf
 1.2 μV (75 ohms)

50 dB quieting sensitivity
 MONO 18.1 dBf
 2.2 μV (75 ohms)
 STEREO 38.1 dBf
 22 μV (75 ohms)

Total harmonic distortion
 wide
 MONO 0.08% (1 kHz)
 STEREO 0.08% (1 kHz)
 narrow
 MONO 0.15% (1 kHz)
 STEREO 0.3% (1 kHz)

S/N MONO 80 dB

Frequency response
 variable 20 Hz ~ 18 kHz
 +0.1, -0.5 dB
 fixed 20 Hz ~ 15 kHz
 +0.2, -0.8 dB

Alternate channel selectivity
 wide 25 dB
 narrow 90 dB

Capture ratio
 wide 0.8 dB
 narrow 2.0 dB

Image rejection at 98 MHz 135 dB

IF rejection at 98 MHz 135 dB

Spurious response rejection at 98 MHz 135 dB

AM suppression (wide) 58 dB

Stereo separation
 wide
 1 kHz 50 dB
 10 kHz 40 dB

narrow
 1 kHz 40 dB
 10 kHz 30 dB

Carrier leak
 variable -65 dB (19 kHz)
 fixed -70 dB (19, 38 kHz)

GENERAL

Output voltage
 variable 0 ~ 1.5 V
 fixed 0.7 V

Power consumption 27 W
 Power supply AC 120 V 60 Hz

Dimensions (H x W x D) 3-31/32" x 19" x 14-9/16"
 (101 x 482 x 370 mm)
 Weight 15.9 lb (7.2 kg)

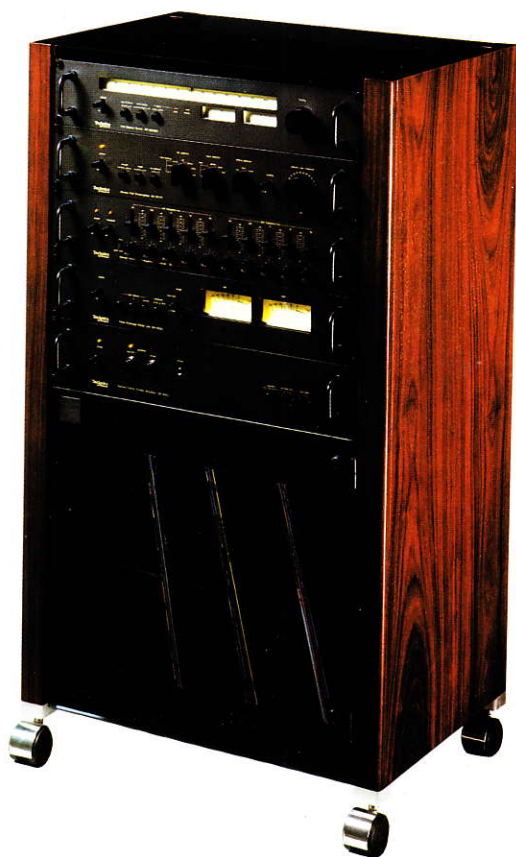

Technics

Panasonic Company

Division of Matsushita Electric Corporation of America

EXECUTIVE OFFICES: One Panasonic Way, Secaucus, New Jersey 07094 (201) 348-7000
 PANASONIC NEW YORK: 50 Meadowlands Parkway, Secaucus, New Jersey 07094 (201) 348-7000
 PANASONIC NEW JERSEY: 50 Meadowlands Parkway, Secaucus, New Jersey 07094 (201) 348-7000
 PANASONIC BOSTON: 75 University Avenue (P.O. Box 487, Norwood, Mass.), Westwood, Massachusetts 02090 (617) 326-4000
 PANASONIC BALTIMORE: 11 Azar Court, Baltimore, Md. 21227 (301) 247-4300
 PANASONIC CHICAGO: 425 East Algonquin Road, Arlington Heights, Ill. 60005 (312) 364-7900
 PANASONIC ATLANTA: 1 Meca Way, Duluth, Georgia 30136 (404) 448-1100
 PANASONIC DALLAS: 1825 Walnut Hill Lane, Irving, Texas 75062 (214) 258-2828
 PANASONIC WEST, INC.: 8383 Wilshire Blvd., Beverly Hills, Calif. 90211 (213) 655-1111
 PANASONIC SALES COMPANY: Ave. 65 de Infantería, Km. 9.7, Victoria Industrial Park, Carolina, Puerto Rico 00630 (809) 769-4320
 PANASONIC HAWAII, INC.: 320 Waiakamilo Road, Honolulu, Hawaii 96817 (808) 847-5361